

10V
5890N

Schublade 1330 / Montagesatz mit 10V9390
Drawer 1330 / Assembly-kit with 10V9390
Tiroir 1330 / Assemble-kit avec 10V9390



ASSEMBLY INSTRUCTION

Montageanleitung • Instructions de montage

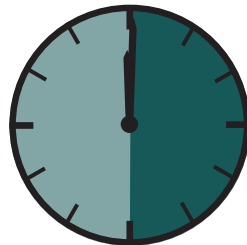

90 Minuten

Product-No.:
10V5890N Black Steel

Revision 6: 05.02.2019



page/Seite 1

10V 5890N

Schublade 1330 / Montagesatz mit 10V9390 Drawer 1330 / Assembly-kit with 10V9390 Tiroir 1330 / Assemble-kit avec 10V9390



Required tools / Benötigte Werkzeuge / Outillage requis

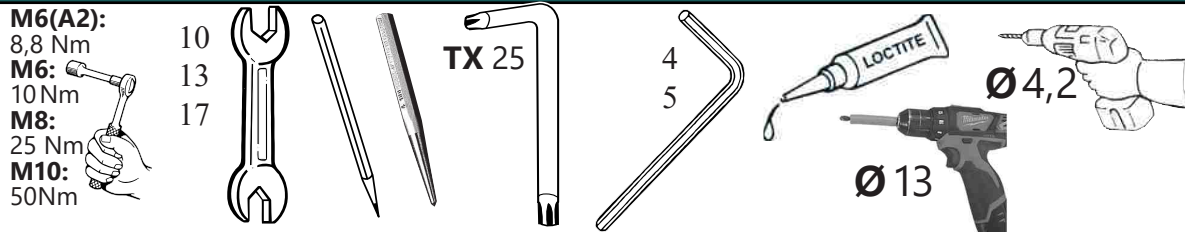

Parts list/Teileliste/Lista de accesorios

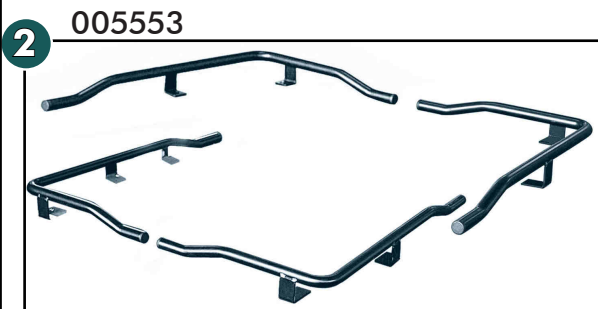
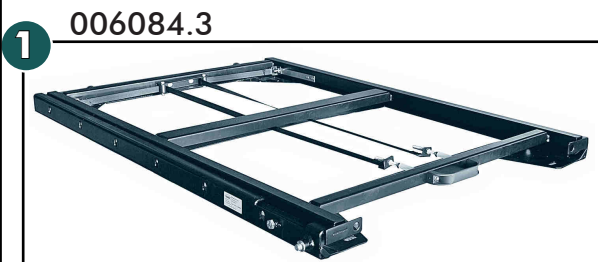

a		ø5,5x25; DIN 7976	2x
b		M6x30; DIN 7991	8x
c		M6x12; ~ISO7380	6x
d		M6x25; ~ISO7380	8x
e		M6x20; DIN 933	2x
f		M8x20; DIN 933	2x
g		M6 weld nut/Anschweißmutter/ soudure écrou	6x
i		ø6,4; DIN 9021	6x
m		M6; DIN 985 Zn	2x
n		M6; DIN 934 Zn	8x

8	ø9; 005497	2x	9	ø6,6; 005495	8x

Assembly-kit / Montagesatz / Assemble-kit

10V9390

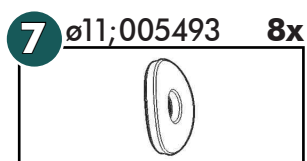
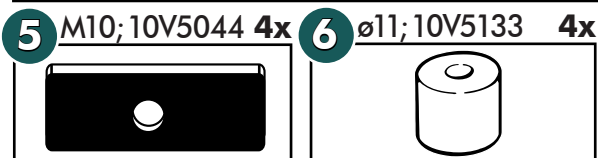

o		M10x60; DIN 933	4x
p		M10; DIN 934	4x

Product-No.:
10V5890N Black Steel

Revision 6: 05.02.2019



4

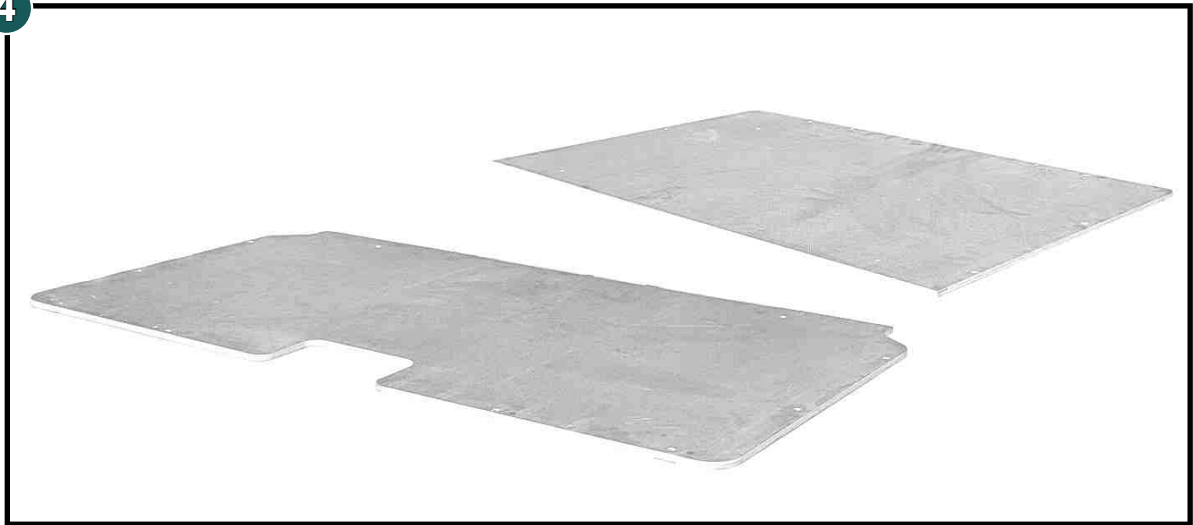

Artikel-Nr. Item-Nr. numéro d'article	KFZ Hersteller auto- motive manufacturer constructeur automobile	Bezeichnung designation désignation	Modell model modèle	Holzauflagen timber vehicle part exigences bois
10V5890N	Mitsubishi	L200 DC	2009 ->	005570N

Product-No.:
10V5890N Black Steel

Revision 6: 05.02.2019



