

**Schublade 1700 / Montagesatz mit 11E9290**  
**Drawer 1700 / Assembly-kit with 11E9290**  
**Tiroir 1700 / Assemble-kit avec 11E9290**

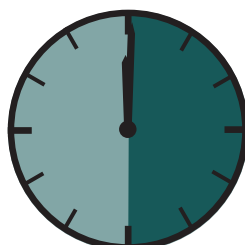

# **ASSEMBLY INSTRUCTION**

**Montageanleitung • Instructions de montage**



**90 Minuten**

**article-no:**  
006085 black Steel

**Revision 5: 07.02.2019**



# Schublade 1700 / Montagesatz mit 11E9290

## Drawer 1700 / Assembly-kit with 11E9290

### Tiroir 1700 / Assemble-kit avec 11E9290



#### Required tools / Benötigte Werkzeuge / Outils requis

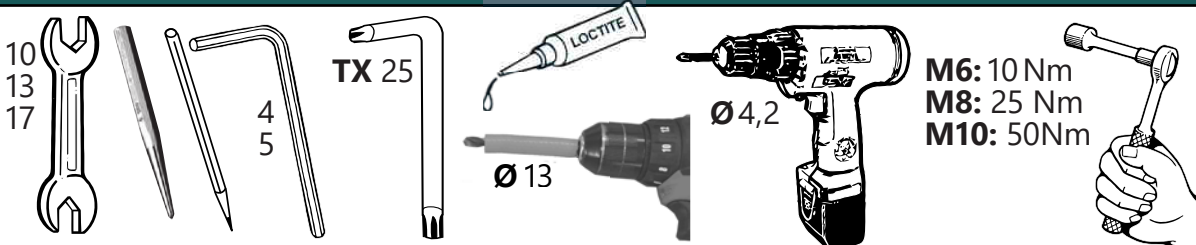

**M6:** 10 Nm  
**M8:** 25 Nm  
**M10:** 50Nm

#### Parts list/Teileliste/Lista de accesorios

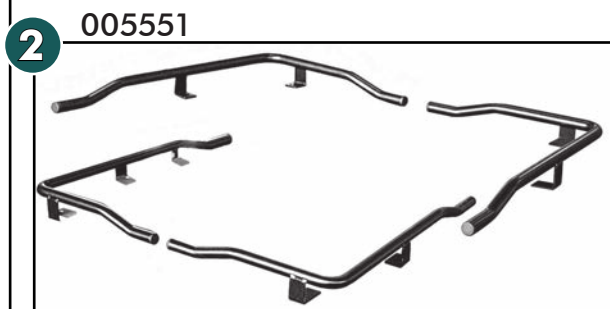

<b>a</b>		ø5,5x25; DIN 7976	<b>2x</b>
<b>b</b>		M6x30; DIN 7991	<b>14x</b>
<b>c</b>		M6x12; ~ISO7380	<b>10x</b>
<b>d</b>		M6x25; ~ISO7380	<b>8x</b>
<b>e</b>		M6x20; DIN 933	<b>2x</b>
<b>f</b>		M8x20; DIN 933	<b>2x</b>
<b>g</b>		M6 weld nut/Anschweißmutter/ soudure écrou	<b>10x</b>
<b>i</b>		ø6,4; DIN 9021	<b>6x</b>
<b>m</b>		M6; DIN 985 Zn	<b>2x</b>
<b>n</b>		M6; DIN 934 Zn	<b>14x</b>

<b>8</b>	ø9; 005497	<b>2x</b>	<b>9</b>	ø6,6; 005495	<b>14x</b>

#### Assembly-kit / Montagesatz / Assemble-kit

**11E9290**

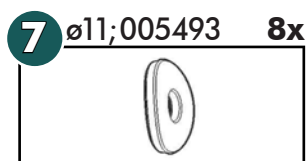
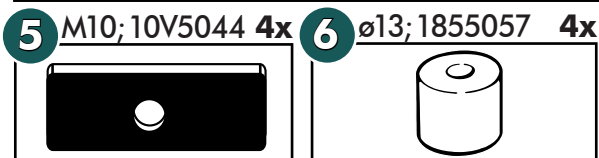

<b>o</b>		M10x60; DIN 933	<b>4x</b>
<b>p</b>		M10; DIN 934	<b>4x</b>

**article-no:**  
006085 black Steel

**Revision 5: 07.02.2019**



**Schublade 1700 / Montagesatz mit 11E9290**  
**Drawer 1700 / Assembly-kit with 11E9290**  
**Tiroir 1700 / Assemble-kit avec 11E9290**



4

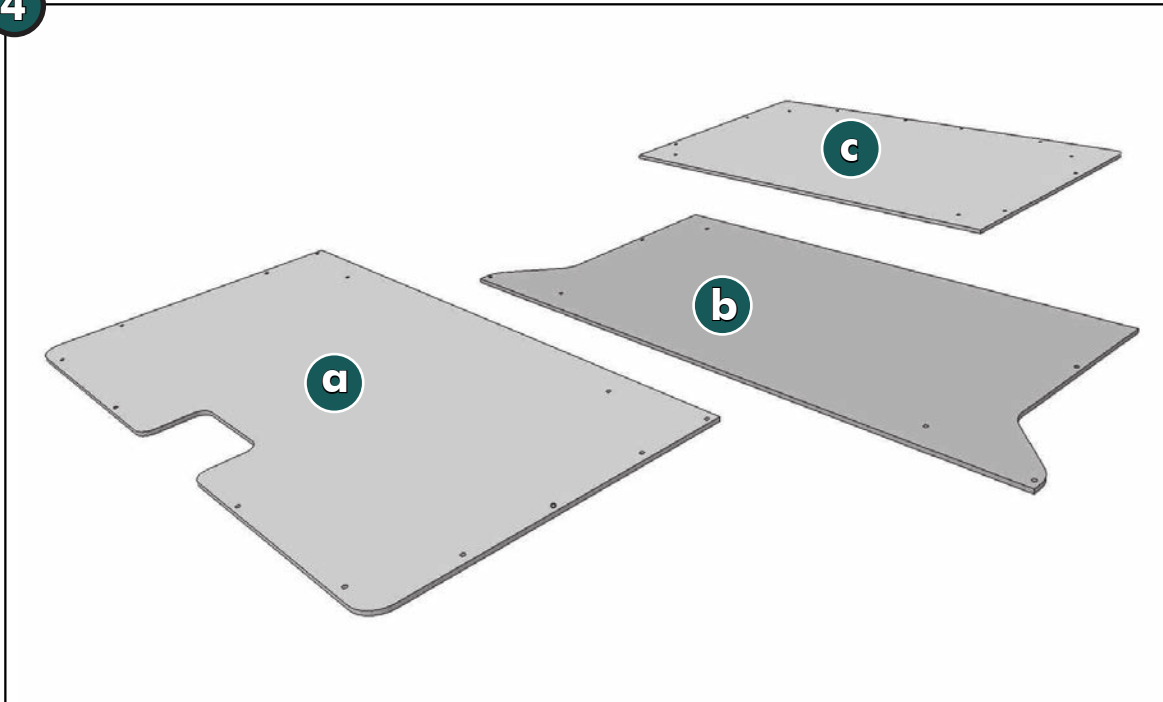

Artikel-Nr. Item-Nr. numéro d'article	KFZ Hersteller auto- motive manufacturer constructeur automobile	Bezeichnung designation désignation	Modell model modèle	Holzauflagen timber vehicle part exigences bois	A	B
11E5890N	Toyota	Hilux Extra Cab	11/2006 ->	005566N	85	217

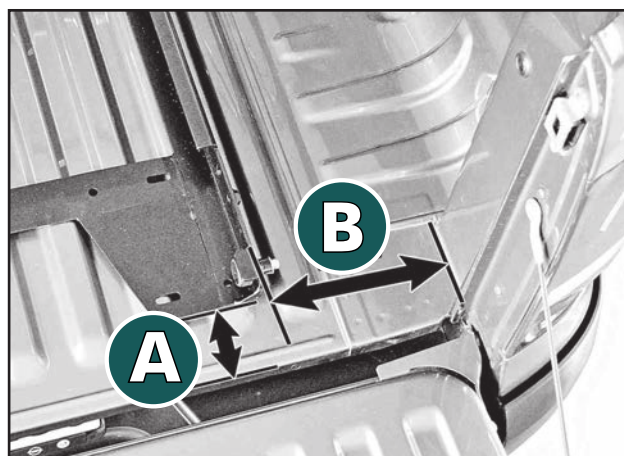

**article-no:**  
006085 black Steel

**Revision 5: 07.02.2019**



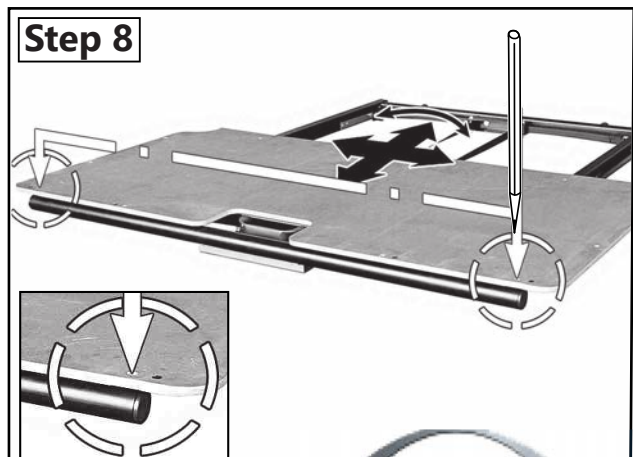
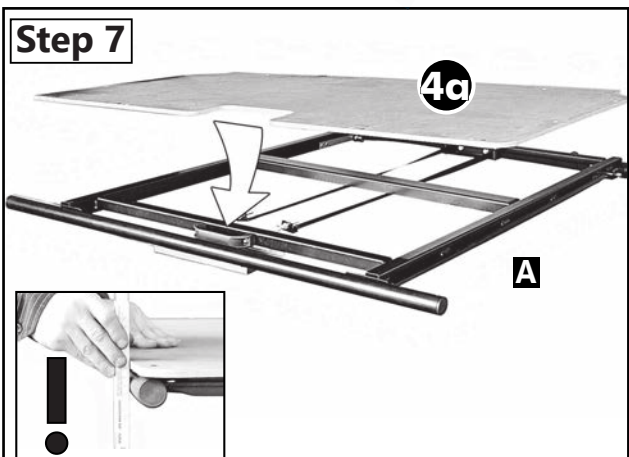
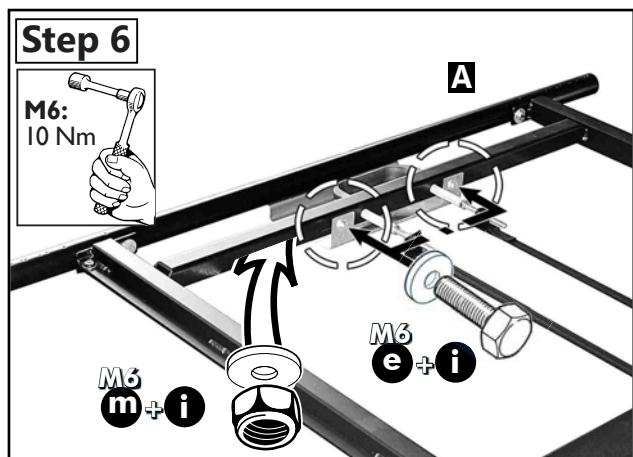
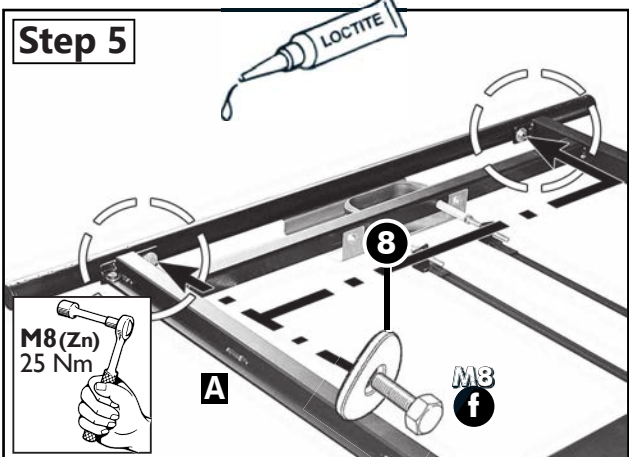
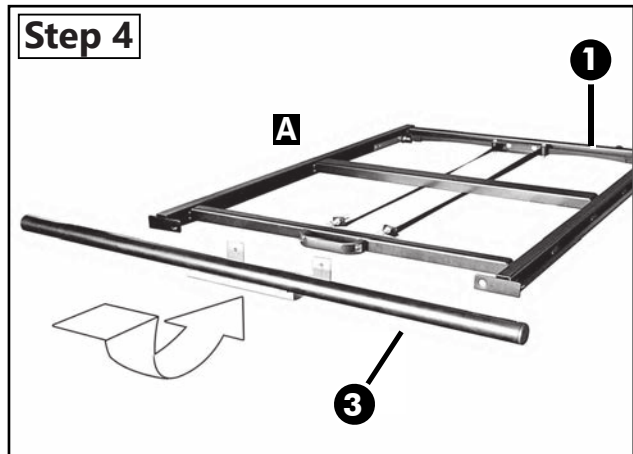
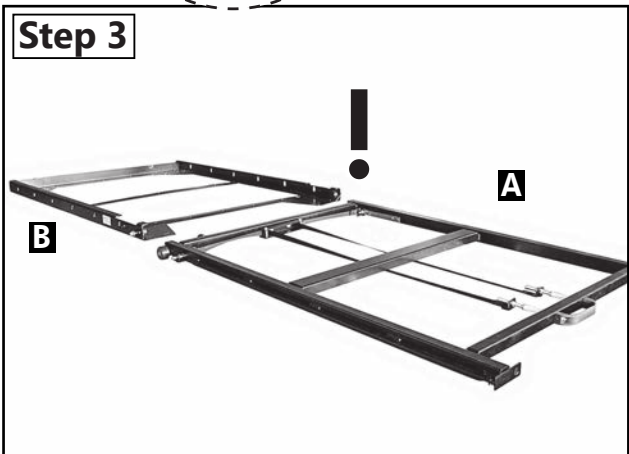
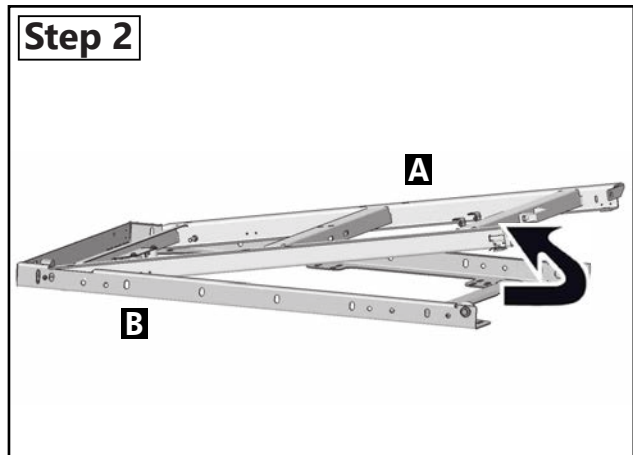
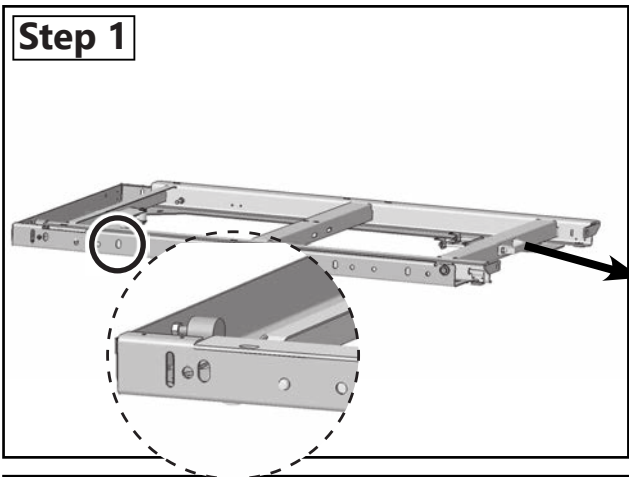

**article-no:**  
006085 black Steel

**Revision 5:** 07.02.2019



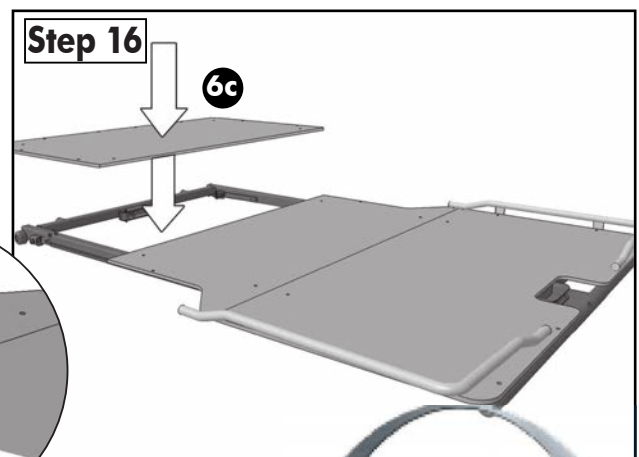
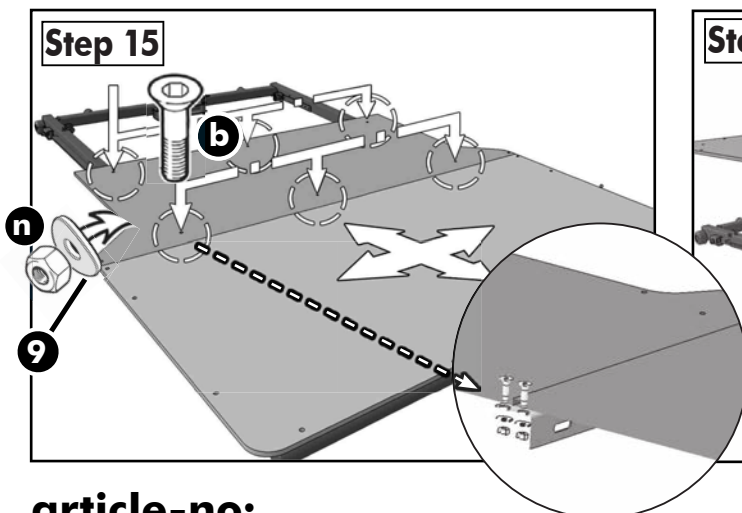
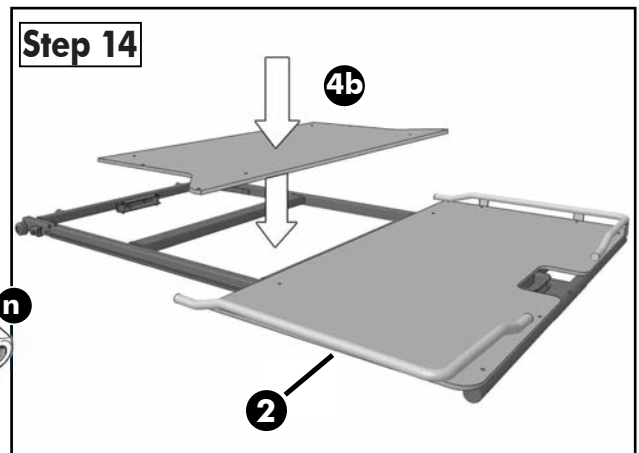
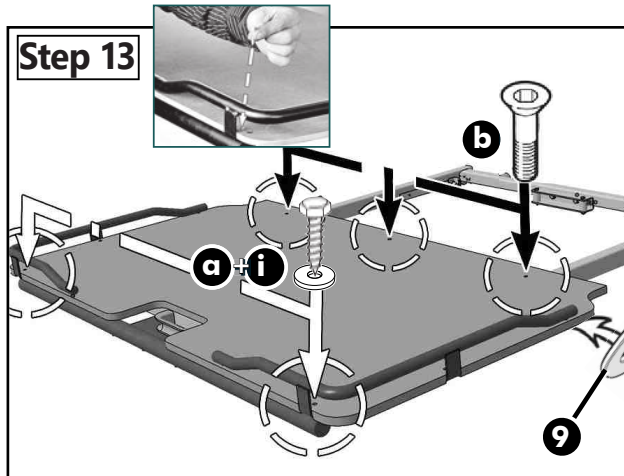
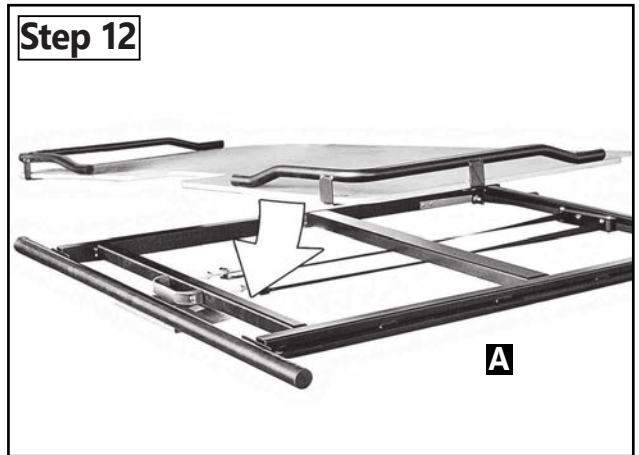
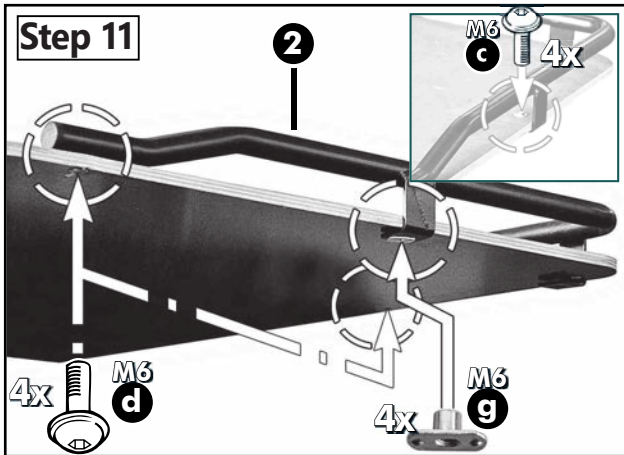
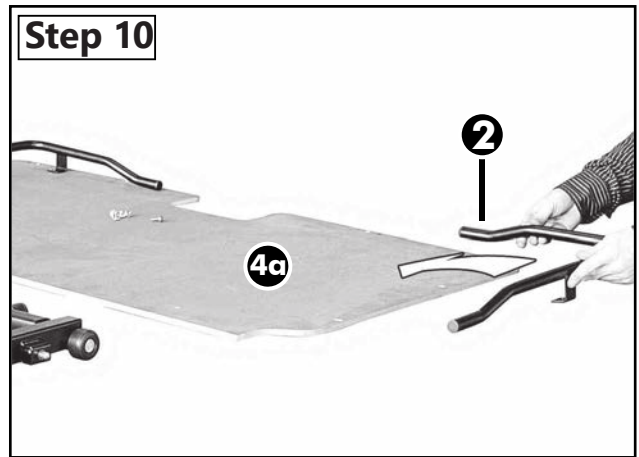
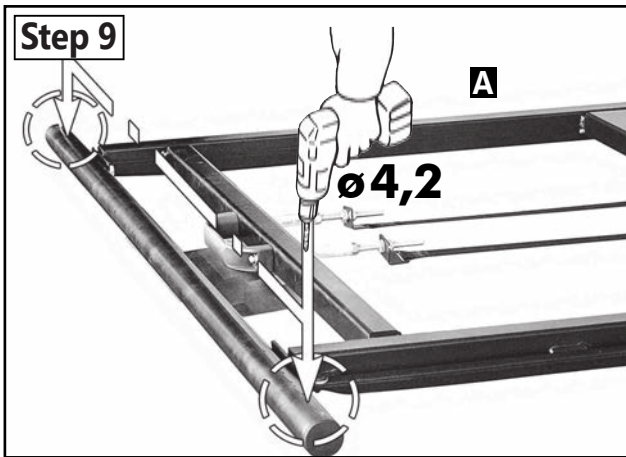

**article-no:**  
006085 black Steel

**Revision 5: 07.02.2019**



**Step 17**

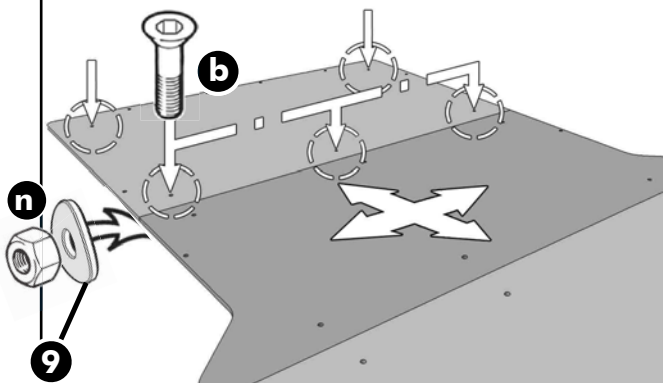

**Step 18**

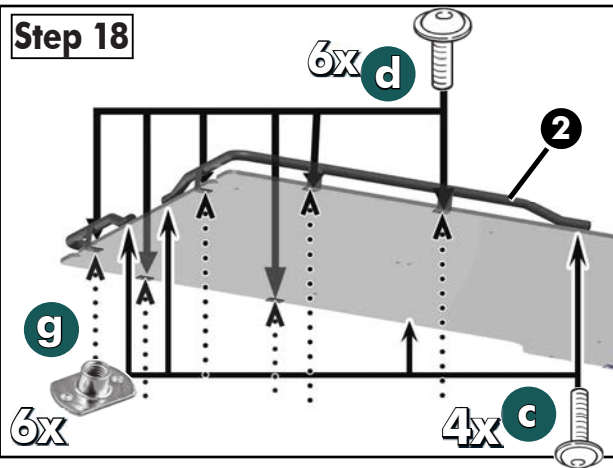

**Step 19**



**Step 20**

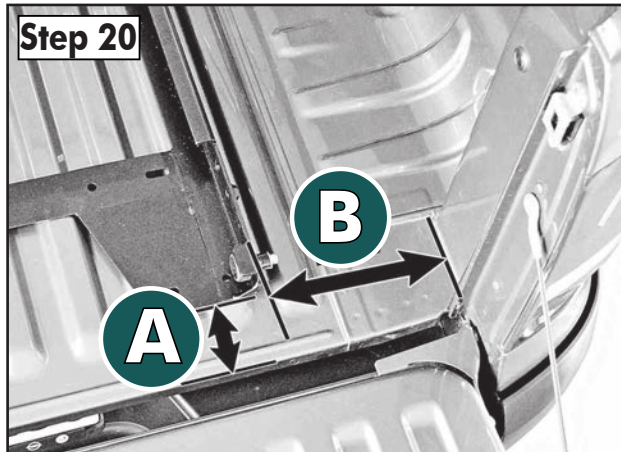

**Step 21**

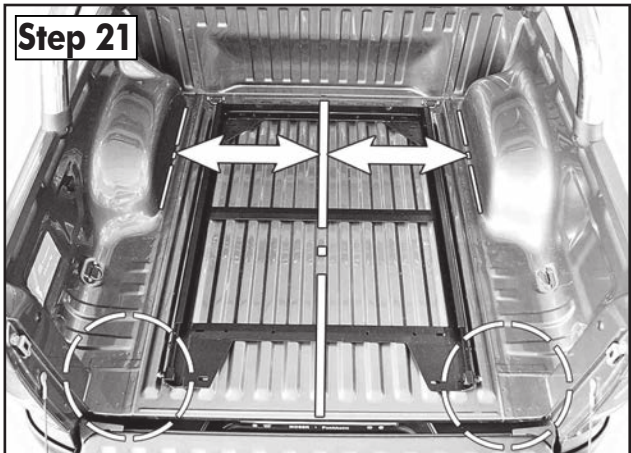

**Step 22**



**Step 23**



**Step 24**

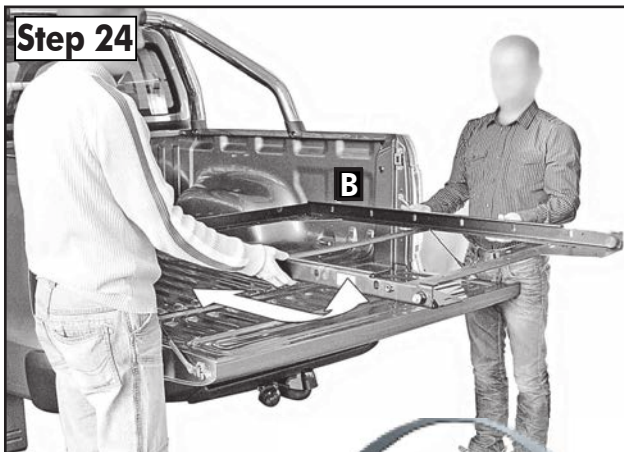

**article-no:**  
006085 black Steel

**Revision 5: 07.02.2019**



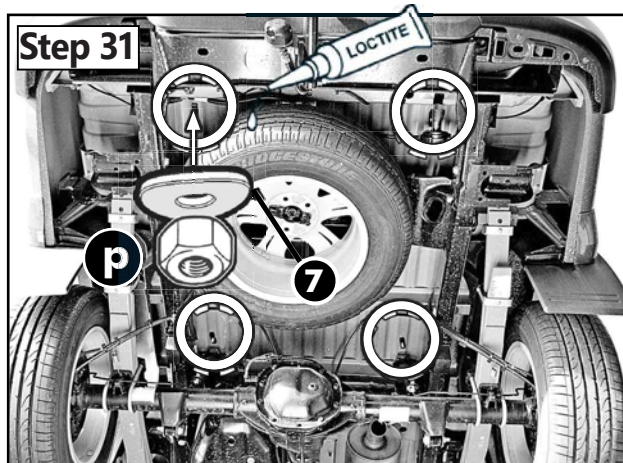
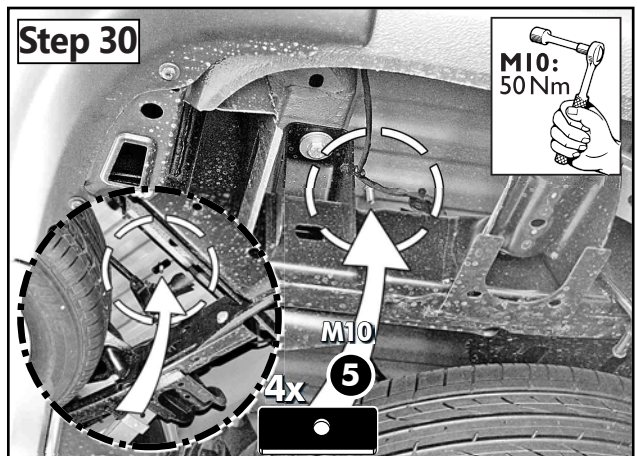
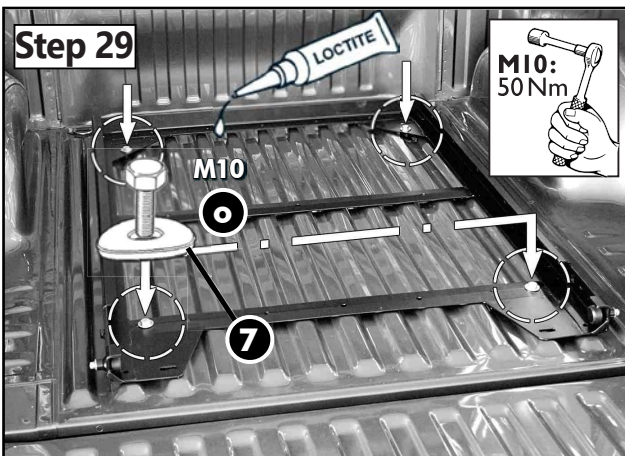
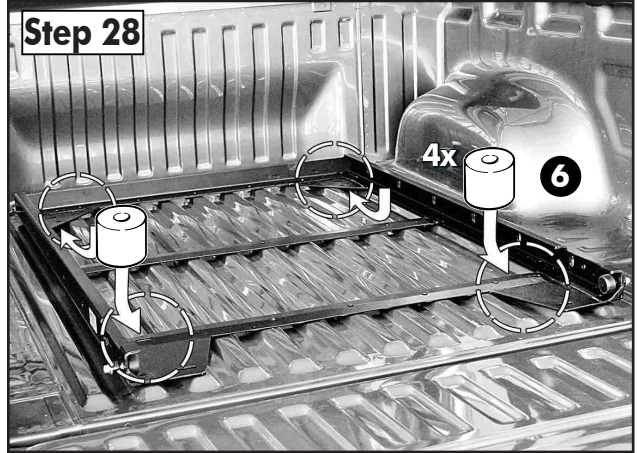
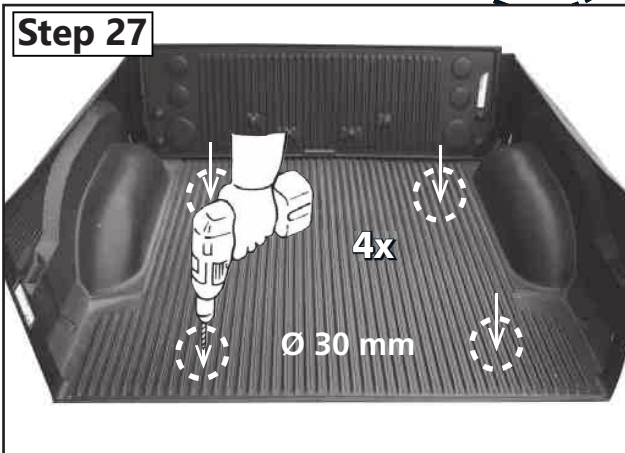
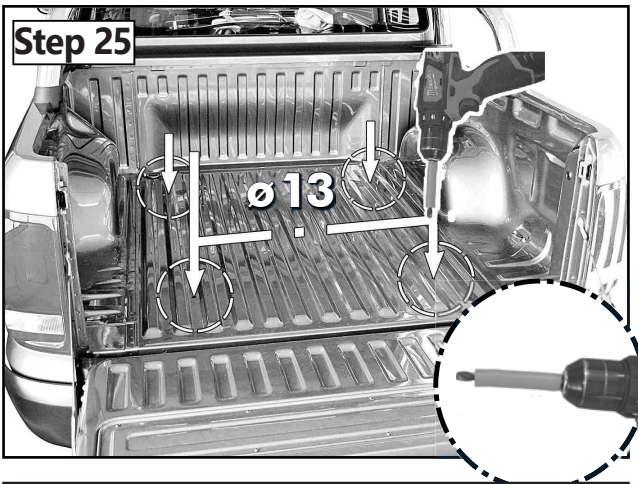

**article-no:**  
006085 black Steel

**Revision 5: 07.02.2019**



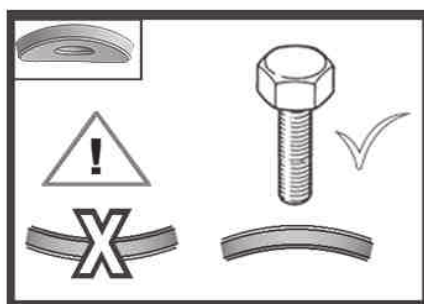
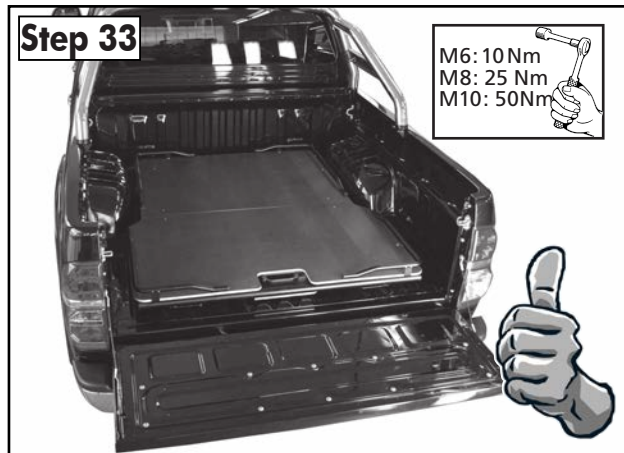
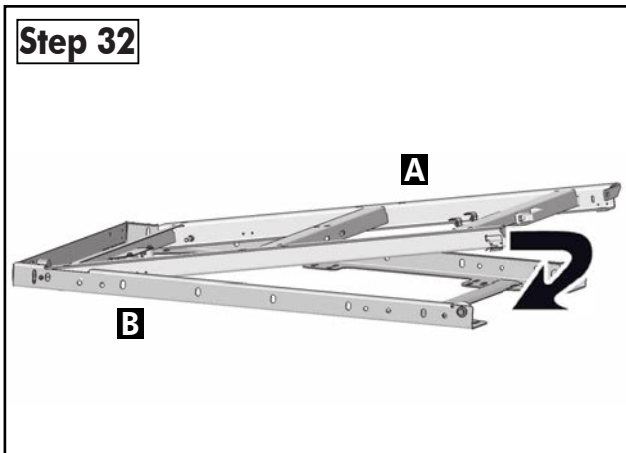

**350 kg  
max**



**article-no:**  
006085 black Steel

**Revision 5:** 07.02.2019

