

11W 4313

Ford Transit, Mod.05/2014+2019

EU-pedestrian protection bar 76 mm

EU-Personenschutzbügel 76 mm

Protection avant, homologuée CEE, 76 mm



*Compatible with Automatic Cruise Control /Forward Collision Mitigation
Kompatibel mit Abstandsregeltempomat /Auffahrvermeidungs-oder warnsystem
compatible avec radar de régulation de distance/ freinage autonome d'urgence

ASSEMBLY INSTRUCTION

Montageanleitung • Instructions de montage



45 Minuten

Artikel-Nr:
11W4313 stainless steel
11W5313 black steel

Revision 6: 05.09.2019



M6: 10 Nm
M8 (A2): 21,4 Nm
M8: 25 Nm

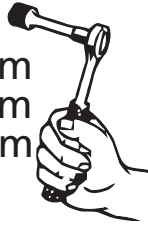

10
13

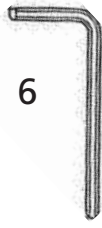

TX 10

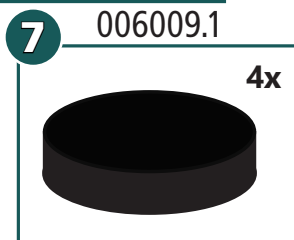
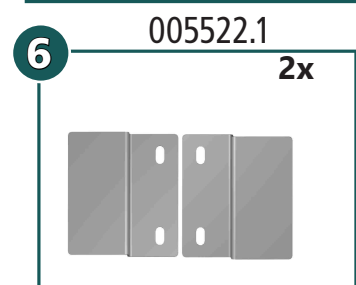
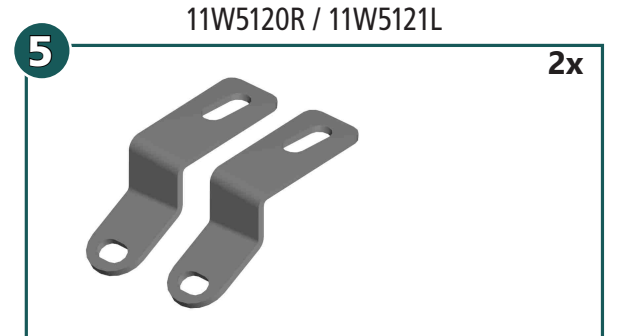
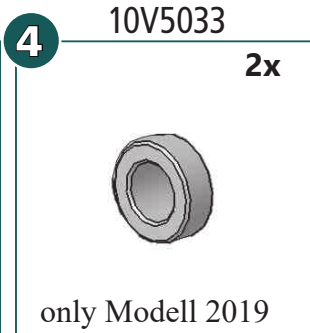
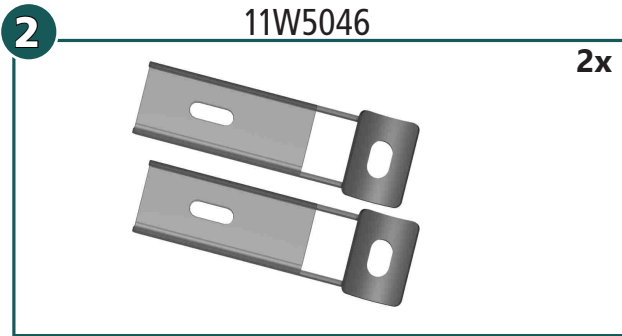
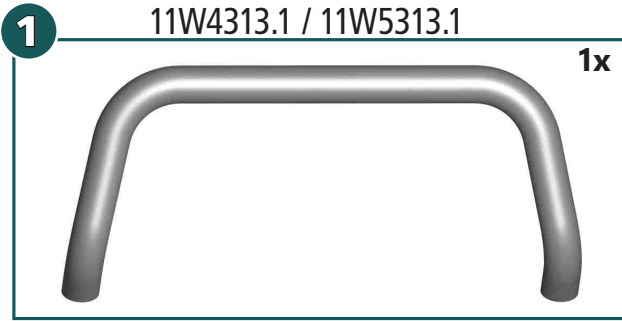

	M6 x 30; DIN 933 Zn	2x
	M8 x 20; DIN 933 A2	2x
	M8 x 55; DIN 933 Zn	2x
	M8 x 25; DIN 7991 A2	2x
	Ø4,8 x 19; DIN 7981 A2	4x
	M8; DIN 934 A2	2x
	Ø5,3; DIN 9021 A2	4x
	Ø 6,4; DIN 9021 Zn	2x
	Ø 8,4; DIN 9021 A2	2x
	SW13	2x

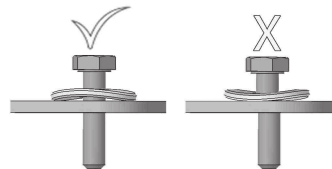
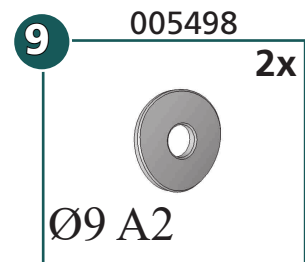
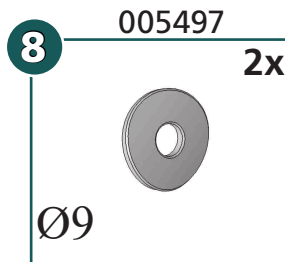

Revision 6: 05.09.2019



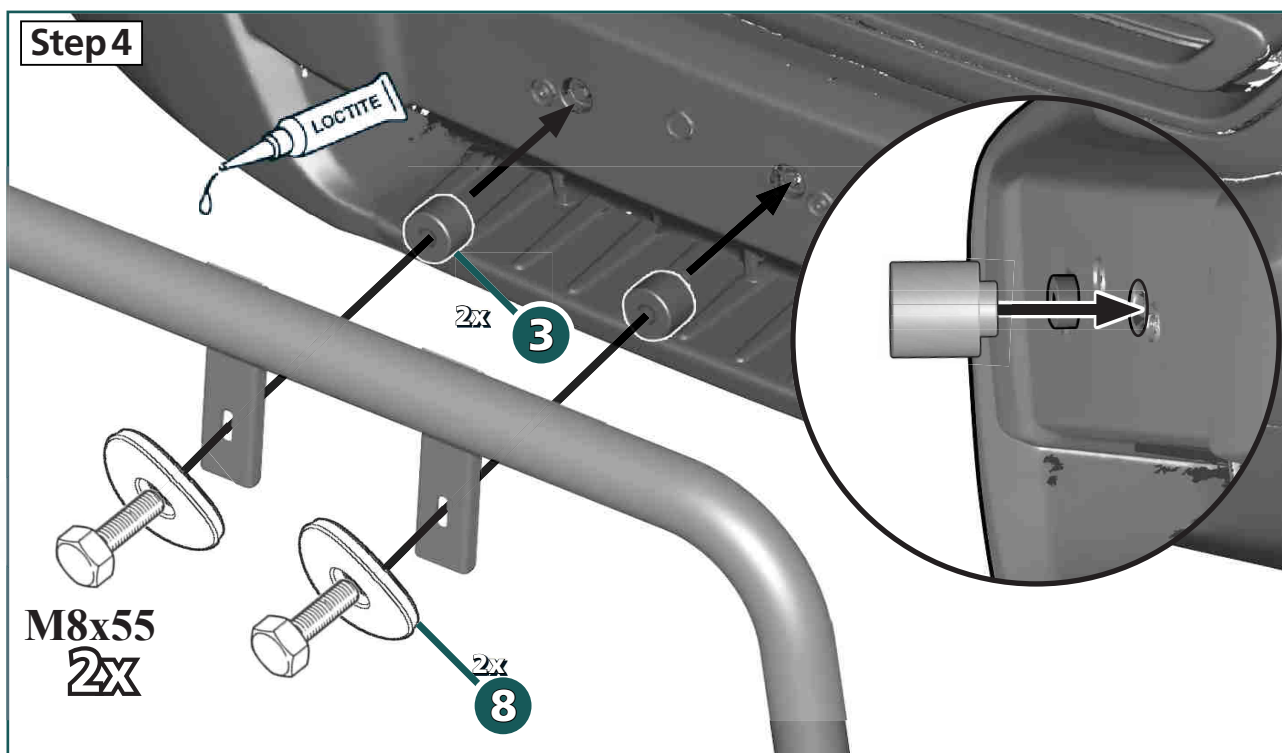
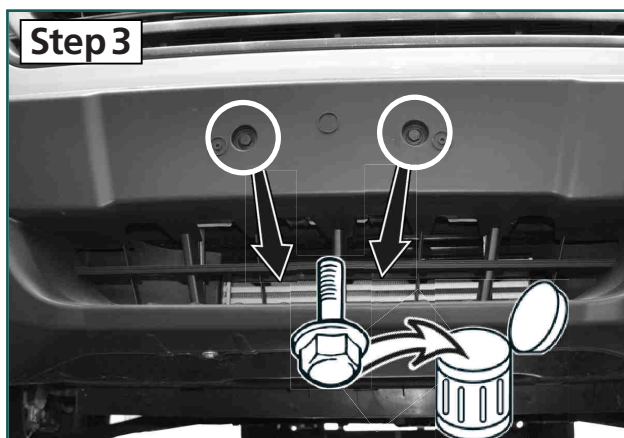
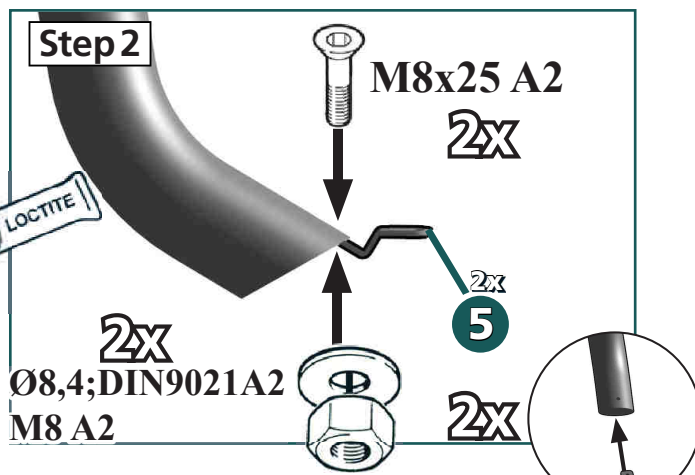
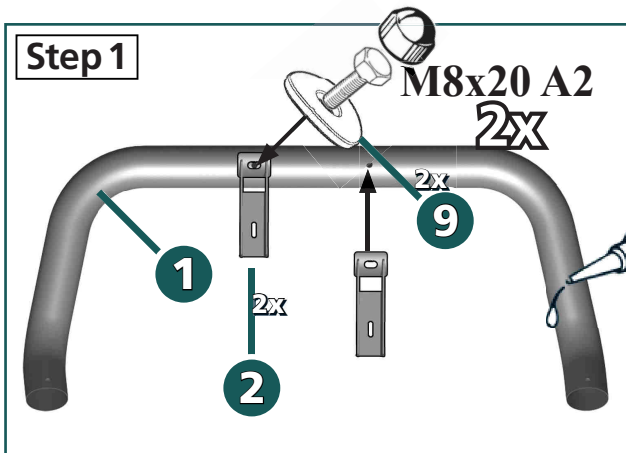

Step 5

Modell 2014

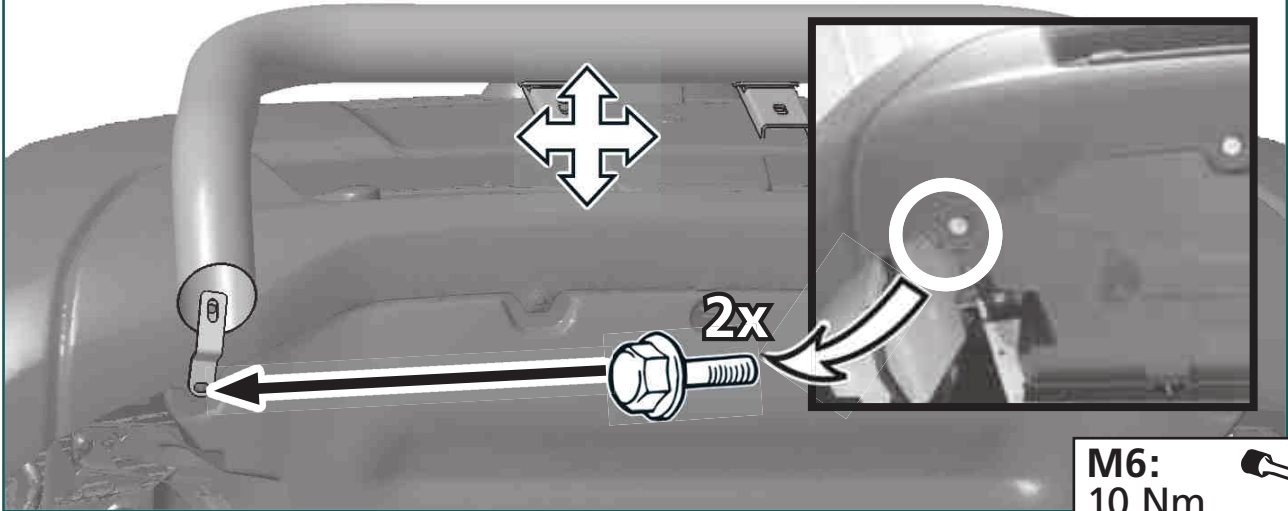

M6:
10 Nm
M8 (A2):
21,4 Nm
M8:
25 Nm



Step 5

Modell 2019

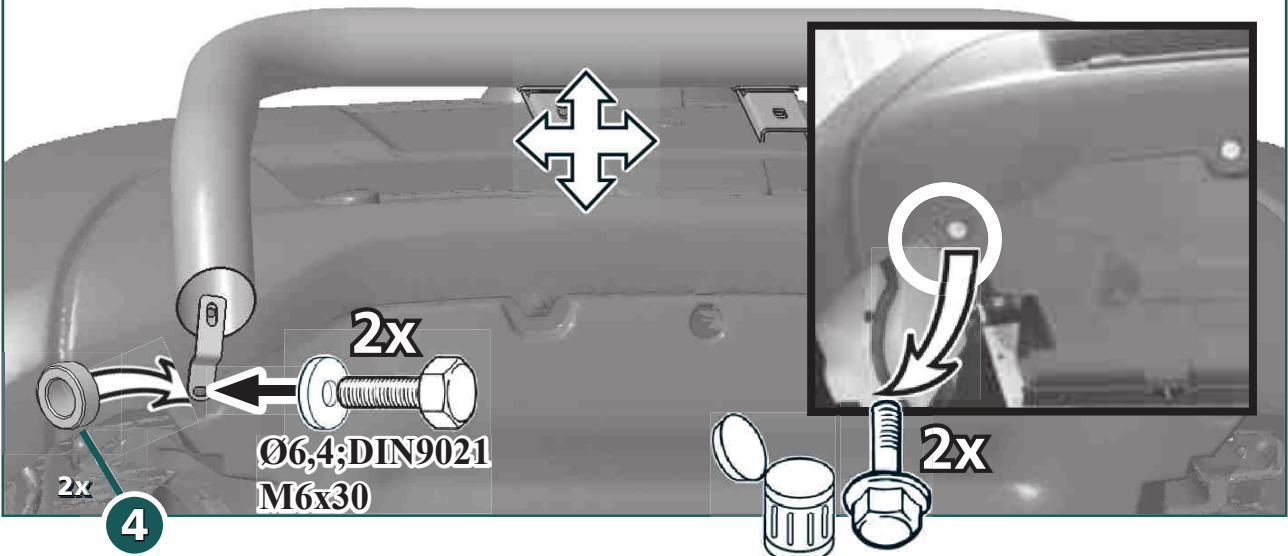

Ø6,4;DIN9021
M6x30

4

Step 6

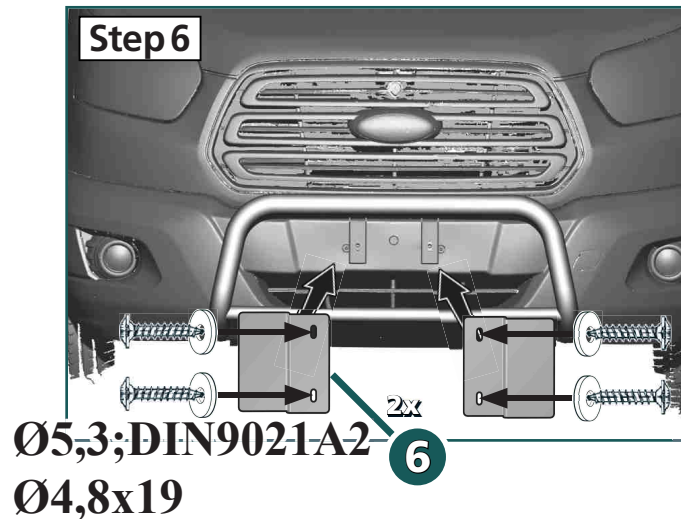

Ø5,3;DIN9021-A2
Ø4,8x19

6

Revision 6: 05.09.2019



