

Hyundai ix35/Tucson/LM; Modell 2010 & 2014

I4L

EU-Personenschutzbügel 60 niedrig mit Querrohr 42

EU-PedestrianProtectionGuard60 low with horizontal pipe 42

Barre de protection des piétons UE de 60 mm avec tube transversal intégré 42 mm



FITTING INSTRUCTIONS

Montageanleitung • Instructions de montage
Instrucciones de montaje • Manual



45 Minuten

Artikel-Nr:

I4L 4113 Stainless Steel

I4L 5113 Steel black

I4L 9013 Mounting Set

Revision 2: 16.11.2011

Hyundai ix35/Tucson/LM; Modell 2010 & 2014

I4L

EU-Personenschutzbügel 60 niedrig mit Querrohr 42

EU-Pedestrian Protection Guard 60 low with horizontal pipe 42

Barre de protection des piétons UE de 60 mm avec tube transversal intégré 42 mm

Required tools / Benötigte Werkzeuge / Outillage requis / Herramientas necesarias

SW: 13 mm

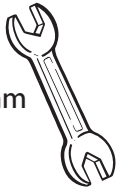

SW: 6 mm



Ø 9 mm

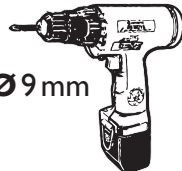

A2:

M8: 21,4 Nm

Zn:

M8: 25 Nm



Parts list / Teileliste / Lista de accesorios

1 I4L4113.1 (I4L5113.1)



Standard Parts list / Normteileliste

a		M8 x20; DIN 933 A2	2x
b		M8 x25; DIN 933	4x
c		M8 x40; DIN 912	2x
d		Ø3,5x13; DIN 7981 A2	2x
e		Ø8; DIN 127 A2	2x
f		Ø8; DIN 127	6x
g		Ø8,4; DIN 9021 A2	2x
h		Ø8,4; DIN 9021	4x
j		Ø8,4; DIN 125	2x
k		Ø4,2; DIN 9021 A2	2x
m		SW 13	6x

Mounting set I4L9013 / Montagesatz I4L9013

2 I4L5024

2x

3 Ø10; I4L5026

4x

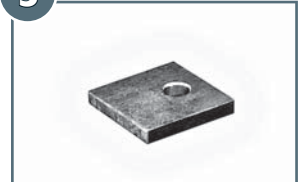

4 Ø11; I365047

2x

5 M8; I825054

2x

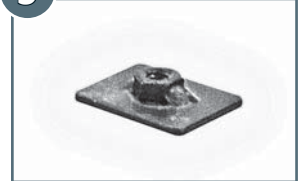
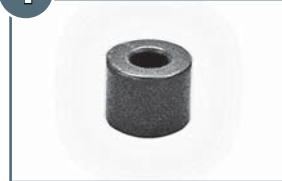

6 IIF8043

2x

7 006009.1

4x

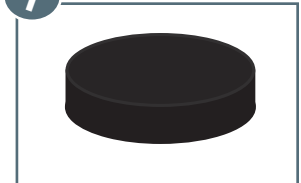

Artikel-Nr:

I4L 4113 Stainless Steel

I4L 5113 Steel black

I4L 9013 Mounting Set

Revision 2: 16.11.2011

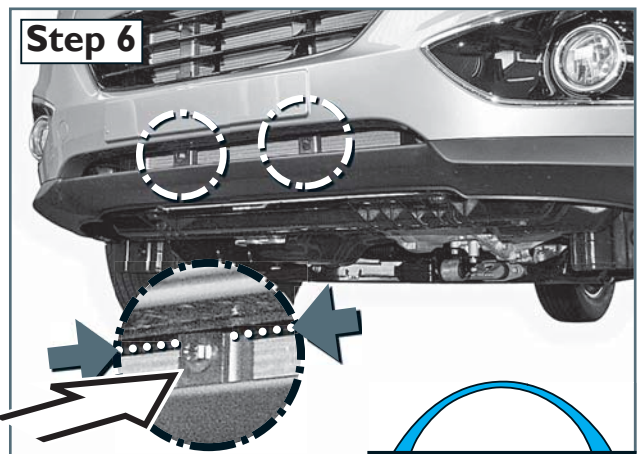
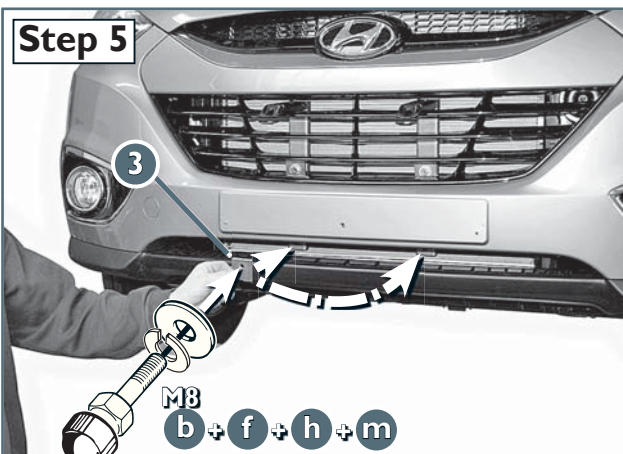
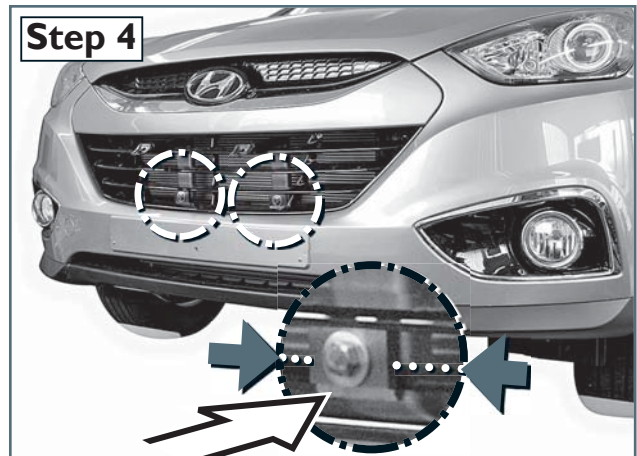
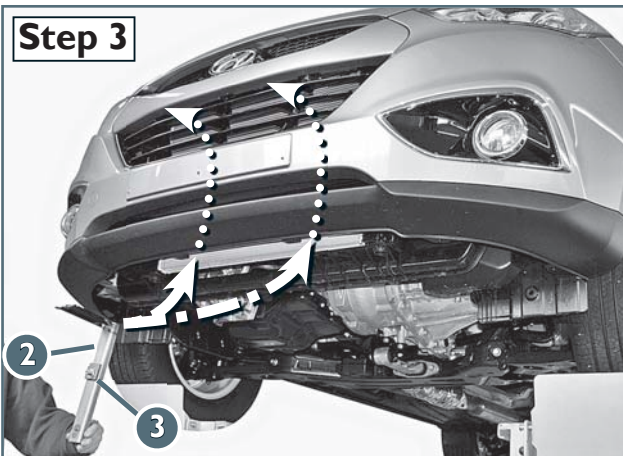
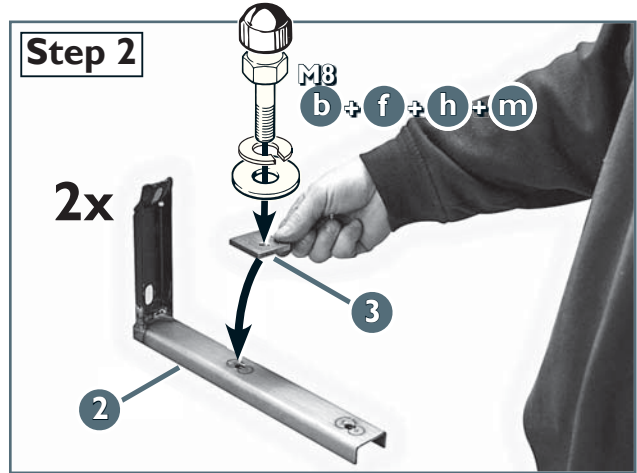
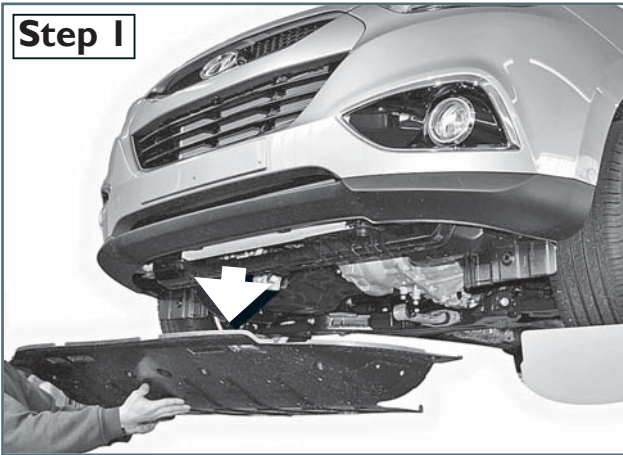

Artikel-Nr:
14L 4113 Stainless Steel

Revision 2: 16.11.2011

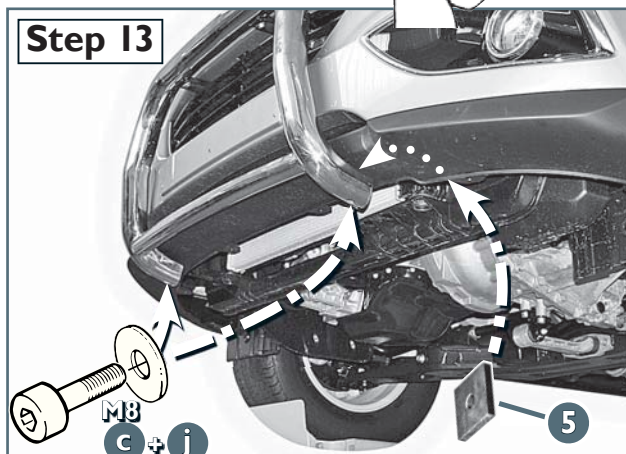
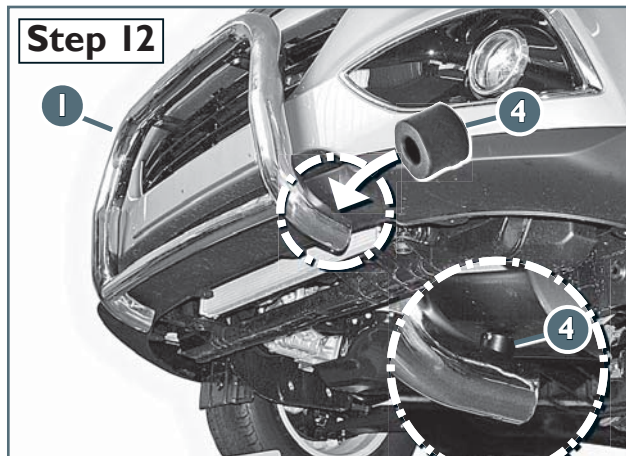
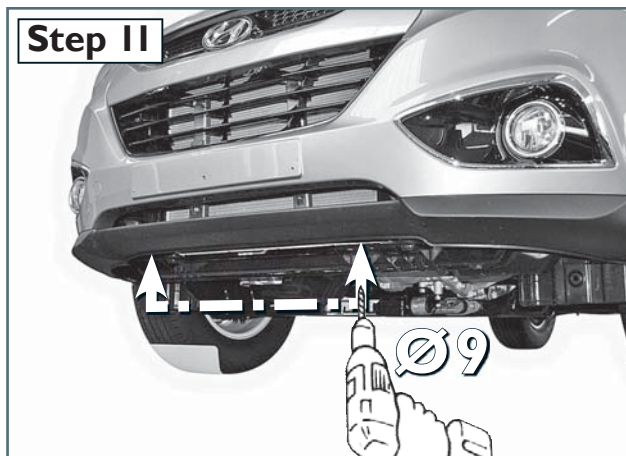
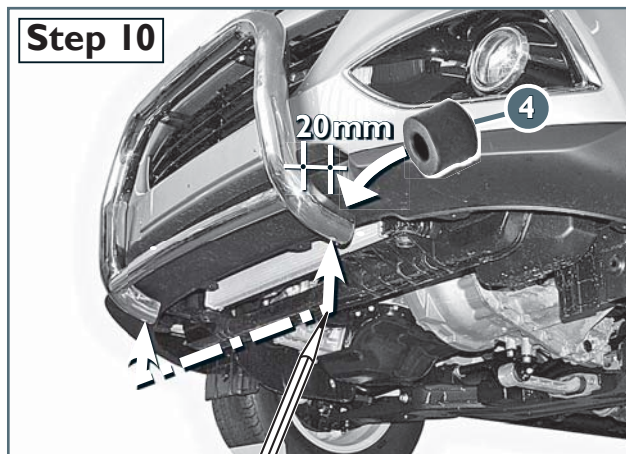
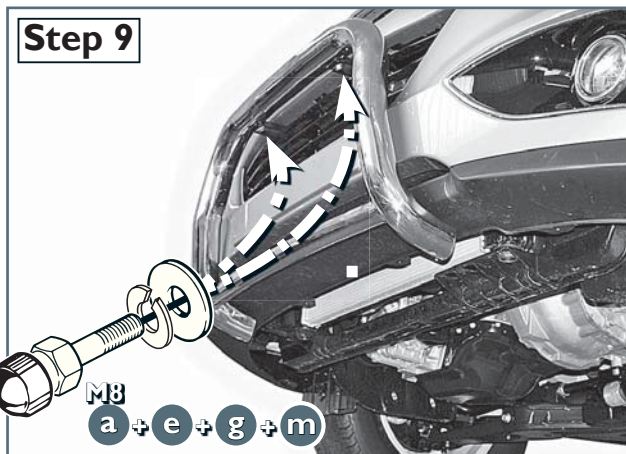
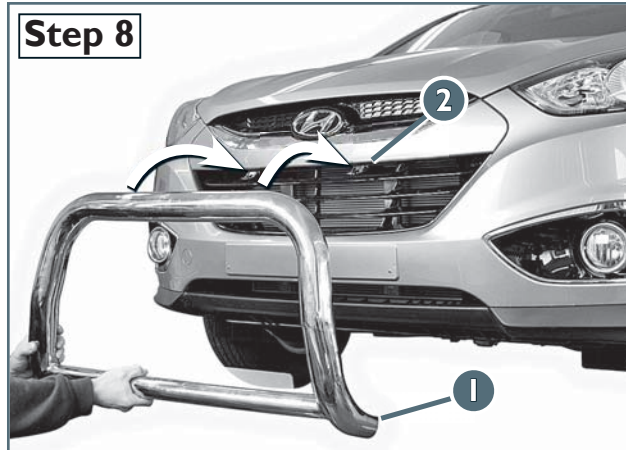
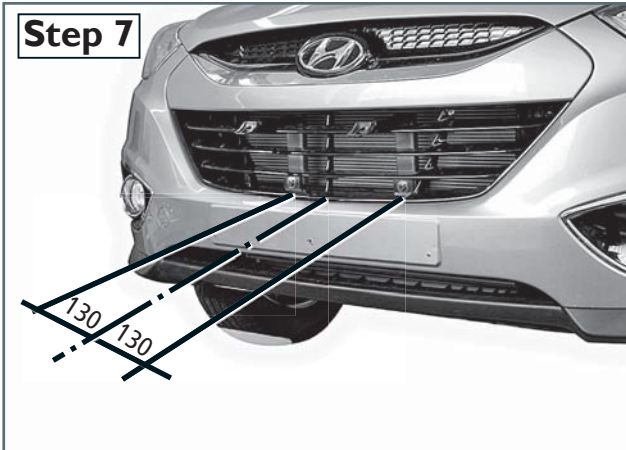

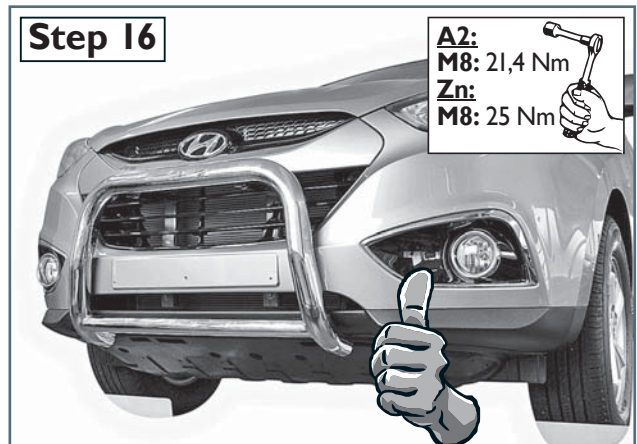
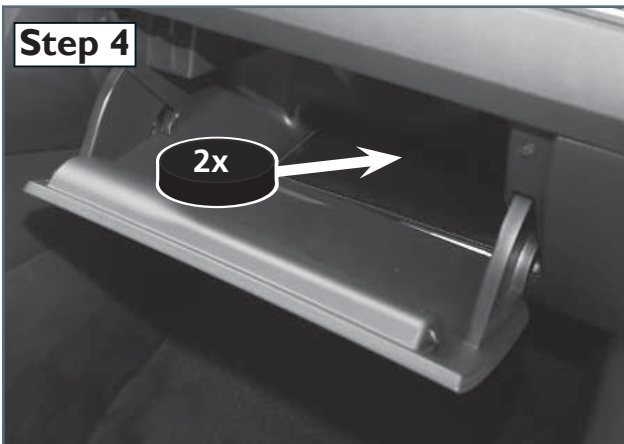
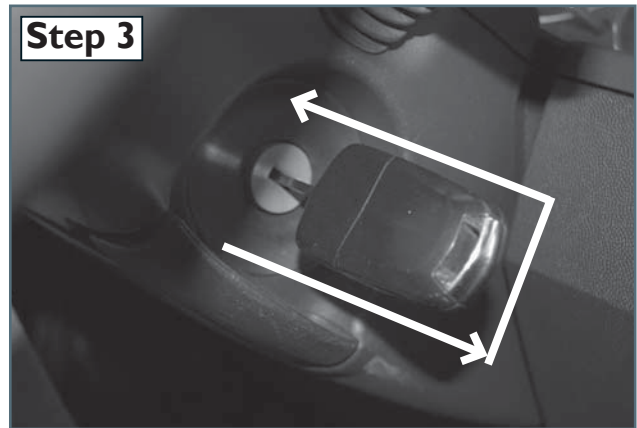
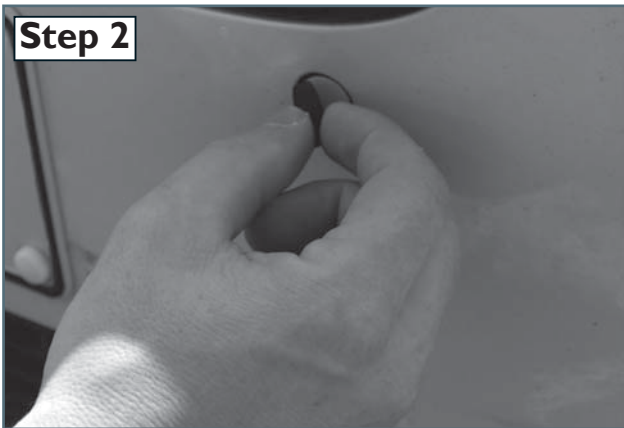
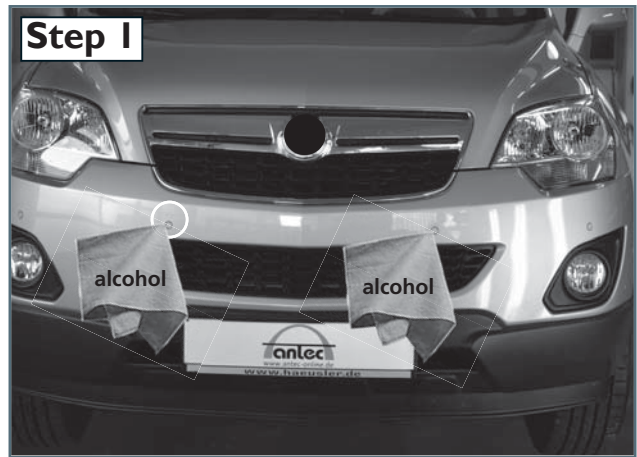
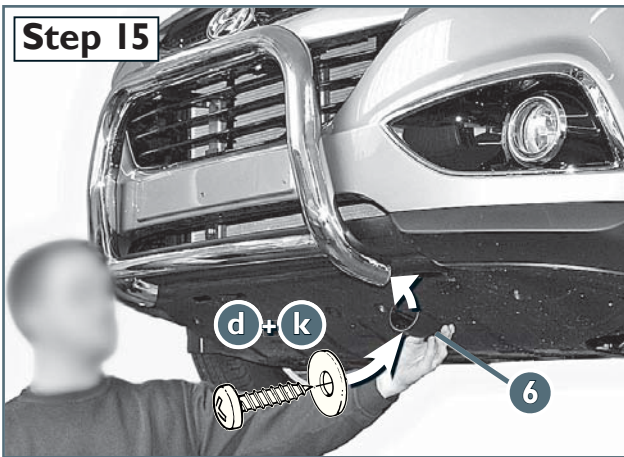

Die Funktion des PDC ist eingeschränkt
 The function of the PDC will be restricted
 La fonction de la pdc est limitée
 La función de la PDC se restringirá
 Funktio PDC on rajoitettu
 Funkce PDC bude omezeno
 Funksjonen til PDC vil være begrenset
 Funktionen för PDC kommer att begränsas

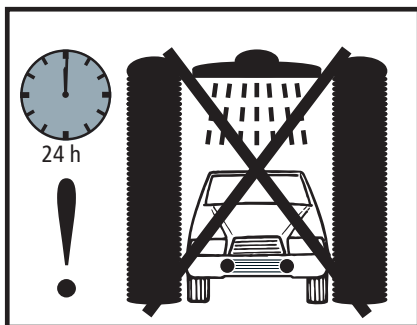

Artikel-Nr:
 14L 4113 Stainless Steel

Revision 2: 16.11.2011