

**15U  
5690N**

**Isuzu D-Max; SpaceCab Md.2012**

Drawer 1700  
Schublade 1700  
Tiroir 1700



# **ASSEMBLY INSTRUCTION**

**Montageanleitung • Instructions de montage**

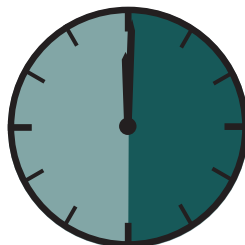

**90 Minuten**

**article-no:**  
15U5690N black

**Revision 6:** 11.02.2019



[www.antec-online.de](http://www.antec-online.de)

# Schublade 1700 / Montagesatz mit 11E9290

## Drawer 1700 / Assembly-kit with 11E9290

### Tiroir 1700 / Assemble-kit avec 11E9290

#### Required tools / Benötigte Werkzeuge / Outillage requis

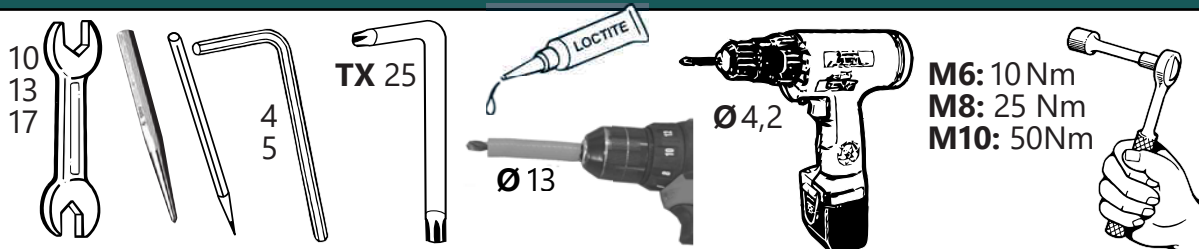

**M6:** 10 Nm  
**M8:** 25 Nm  
**M10:** 50 Nm



#### Parts list/Teileliste/Lista de accesorios

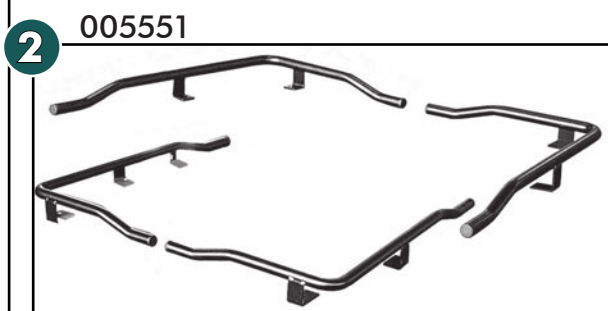

<b>a</b>		ø5,5x25; DIN 7976	<b>2x</b>
<b>b</b>		M6x30; DIN 7991	<b>14x</b>
<b>c</b>		M6x12; ~ISO7380	<b>10x</b>
<b>d</b>		M6x25; ~ISO7380	<b>8x</b>
<b>e</b>		M6x20; DIN 933	<b>2x</b>
<b>f</b>		M8x20; DIN 933	<b>2x</b>
<b>g</b>		M6 weld nut/Anschweißmutter/ soudure écrou	<b>10x</b>
<b>i</b>		ø6,4; DIN 9021	<b>6x</b>
<b>m</b>		M6; DIN 985 Zn	<b>2x</b>
<b>n</b>		M6; DIN 934 Zn	<b>14x</b>

**8** ø9; 005497 **2x**    **9** ø6,6; 005495 **14x**

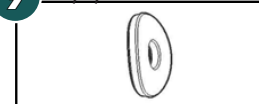
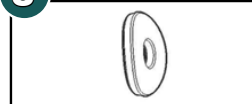

#### Assembly-kit / Montagesatz / Assemble-kit

**11E9290**

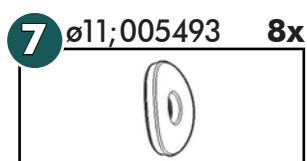
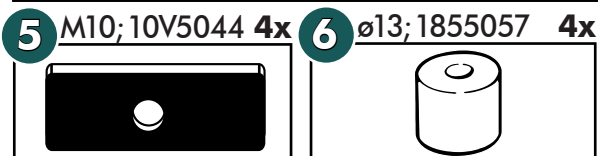

<b>o</b>		M10x60; DIN 933	<b>4x</b>
<b>p</b>		M10; DIN 934	<b>4x</b>

**article-no:**  
15U5690N black

**Revision 6:** 11.02.2019



**Schublade 1700 / Montagesatz mit 11E9290**  
**Drawer 1700 / Assembly-kit with 11E9290**  
**Tiroir 1700 / Assemble-kit avec 11E9290**

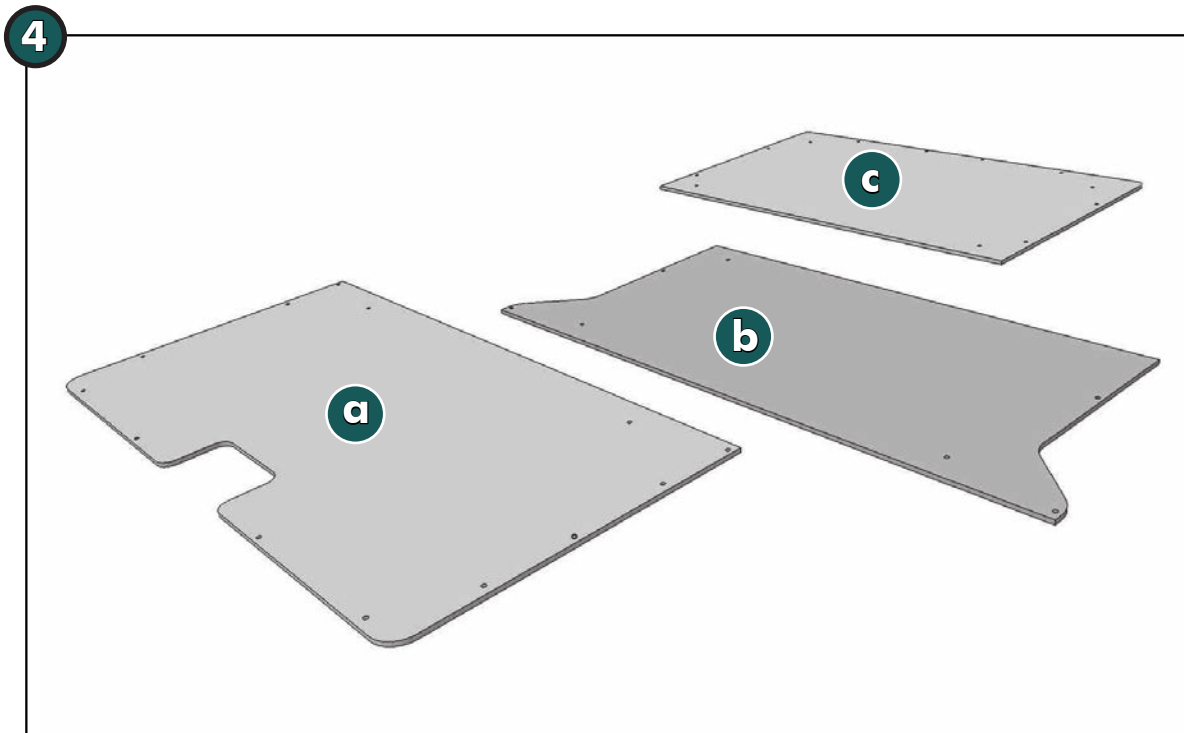

Artikel-Nr. Item-Nr. numéro d'article	KFZ Hersteller auto- motive manufacturer constructeur automo- bile	Bezeichnung designation désignation	Modell model modèle	Holzauflagen timber vehicle part exigences bois
15U5690N	Isuzu	D MAX Space Cab	2012	007769N

**article-no:**  
15U5690N black



**Revision 6:** 11.02.2019



# 15U 9790

## Isuzu D-Max; Md.2012

Drawer 1700  
Schublade 1700  
Tiroir 1700

15U 9790			
<b>c</b>		M6x12; ~ISO7380	<b>2x</b>
<b>g</b>		M6 weld nut/Anschweißmutter/ soudure écrou	<b>2x</b>

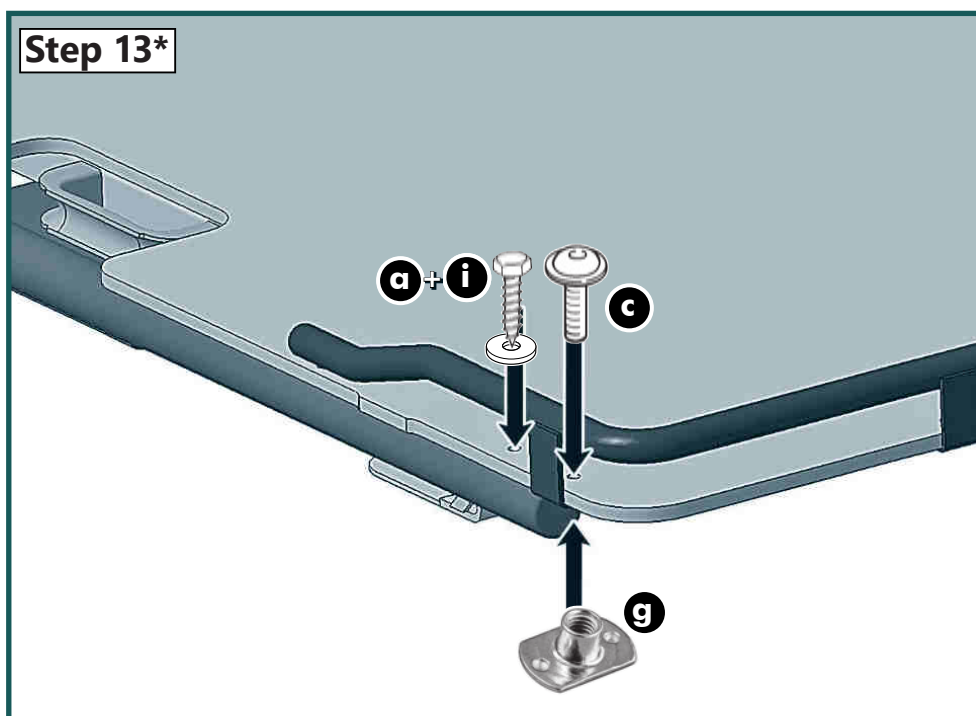

**Product-No.:**  
15U5690N

**Revision 6:** 11.02.2019

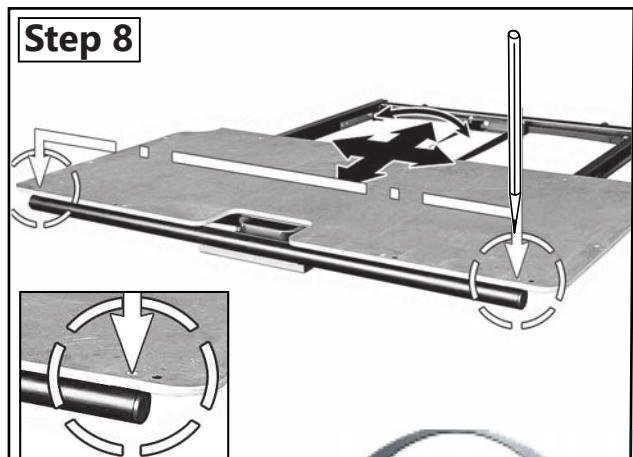
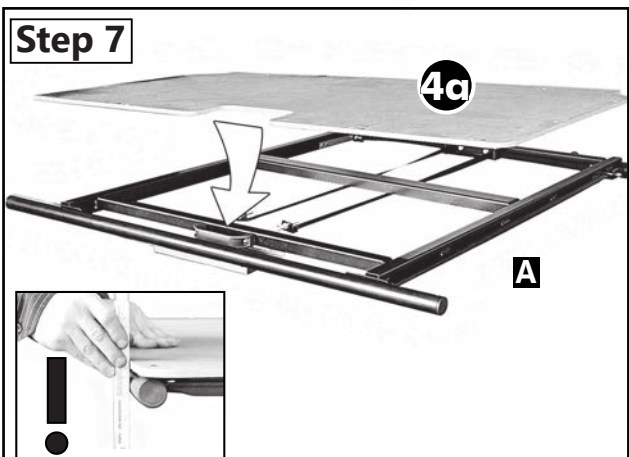
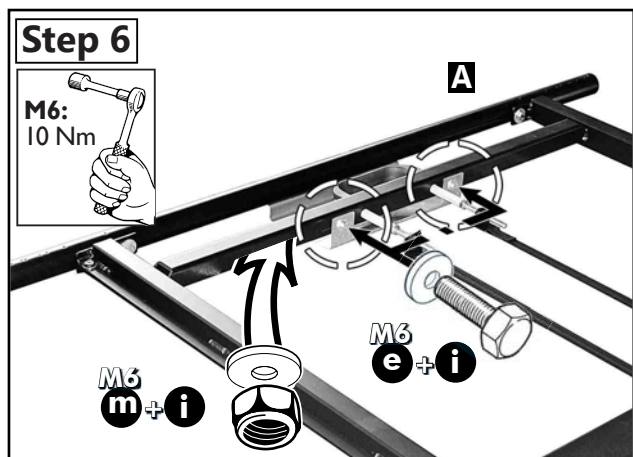
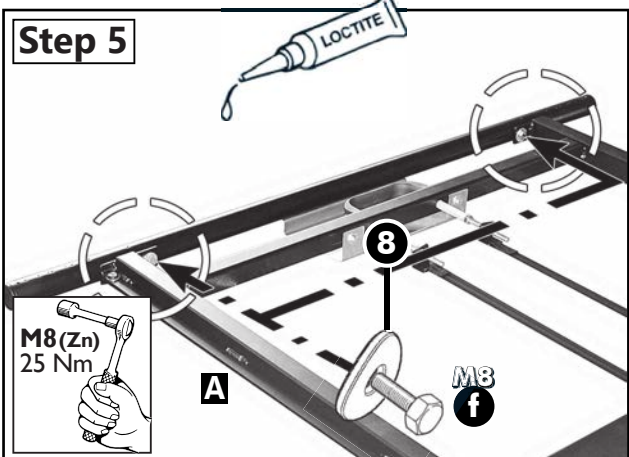
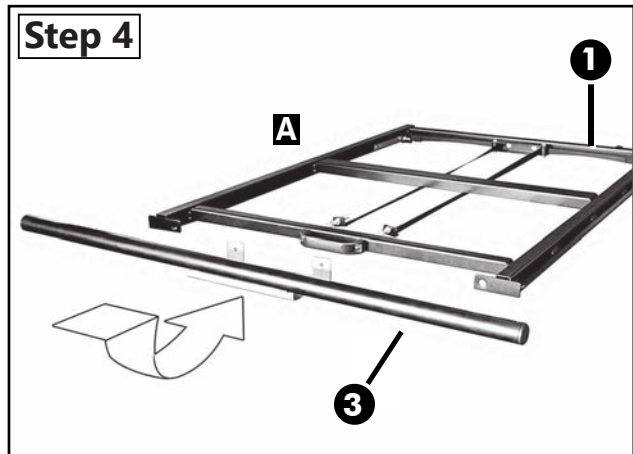
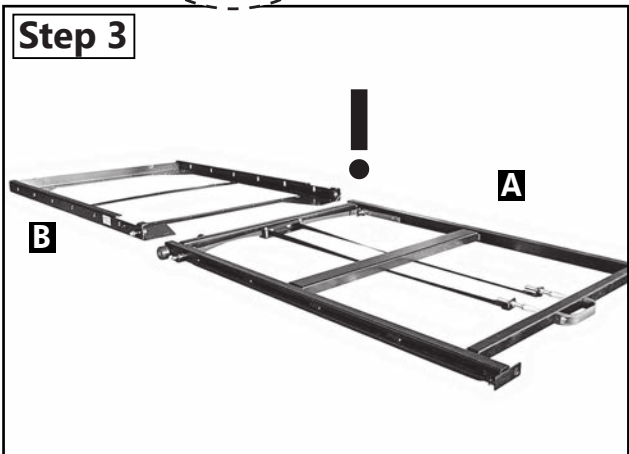
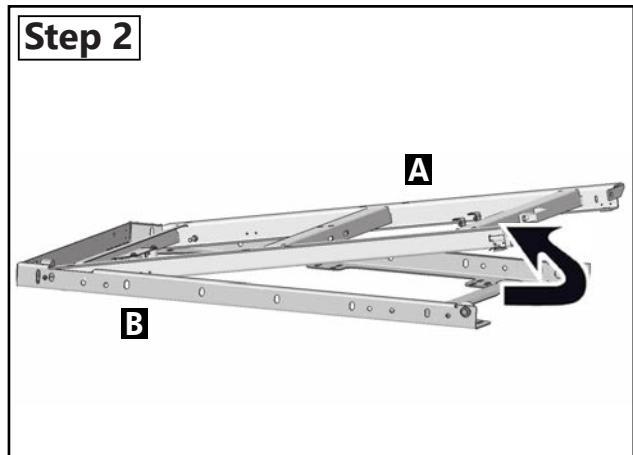
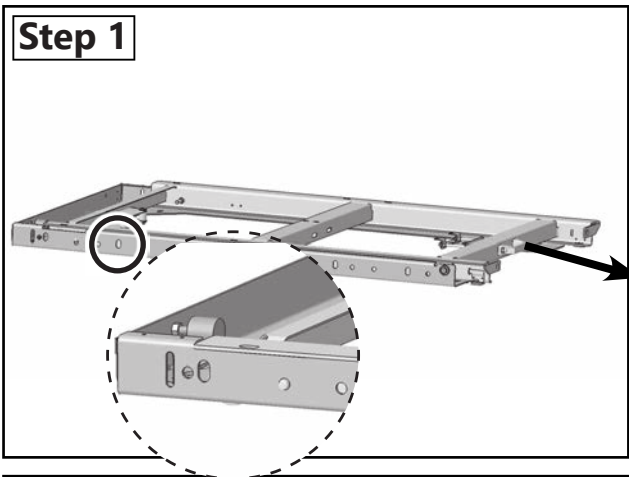

**article-no:**  
15U5690N black

**Revision 6:** 11.02.2019



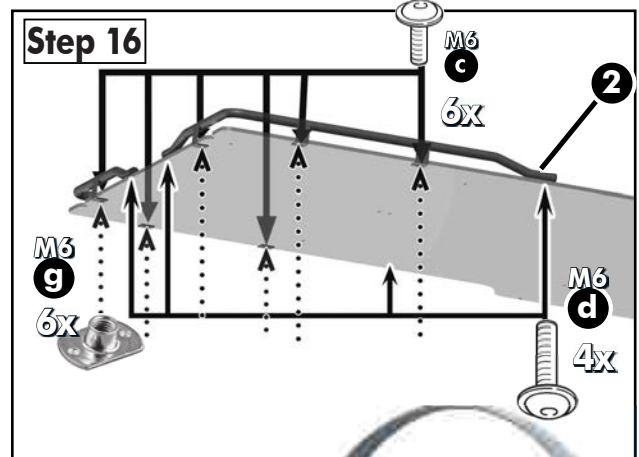
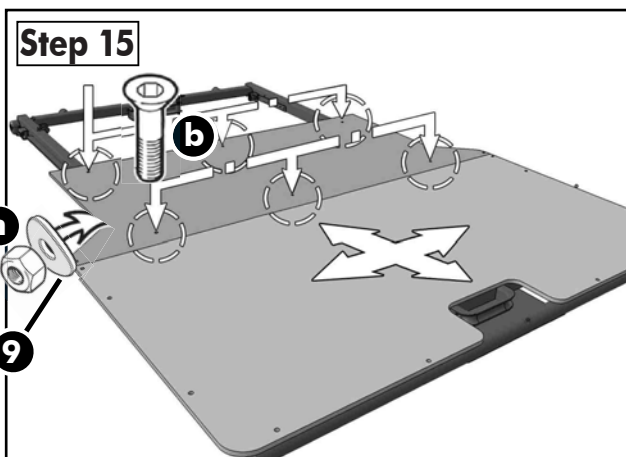
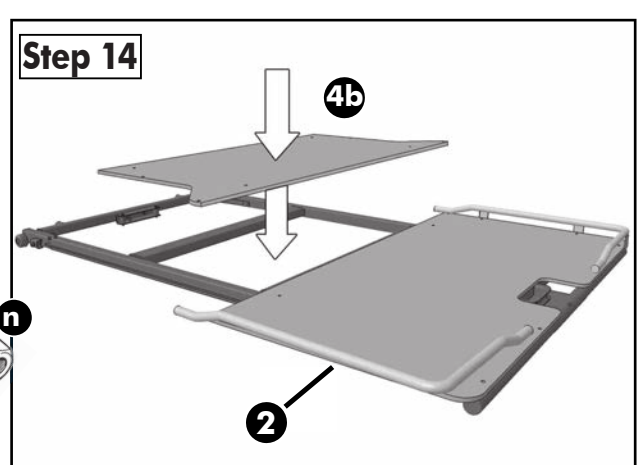
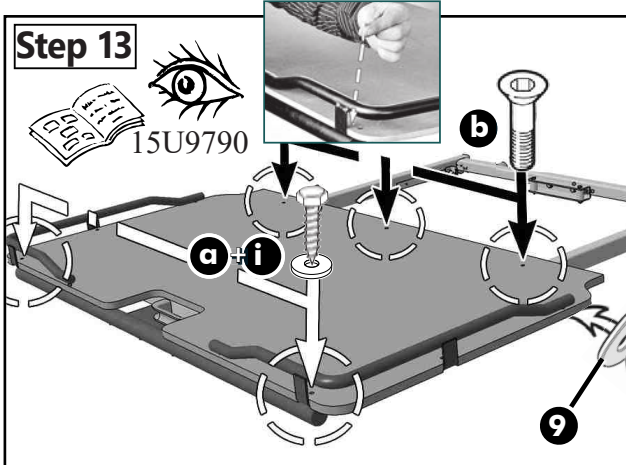
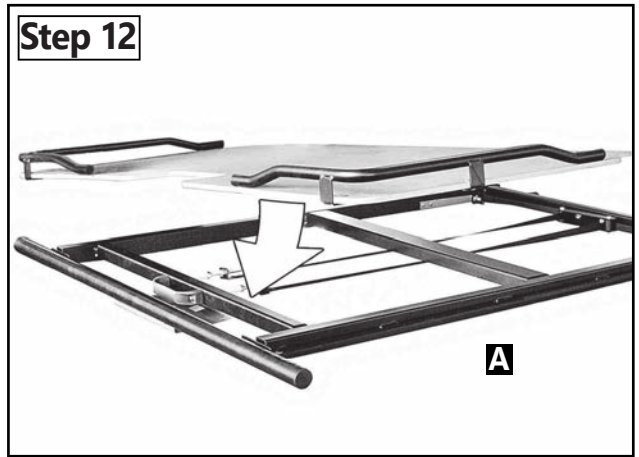
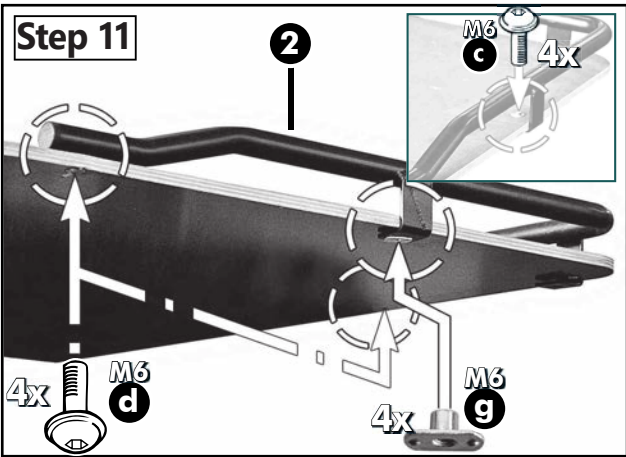
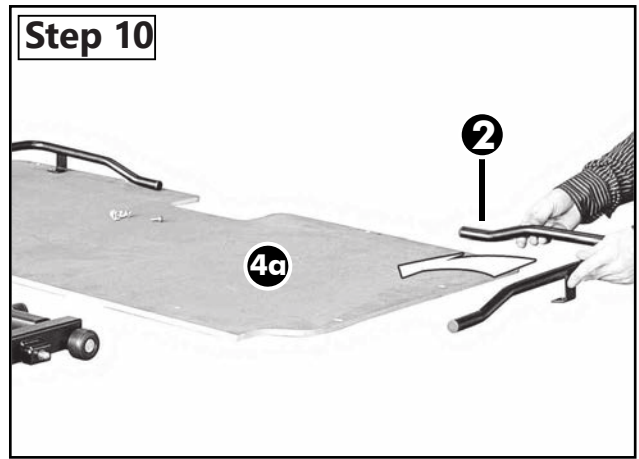
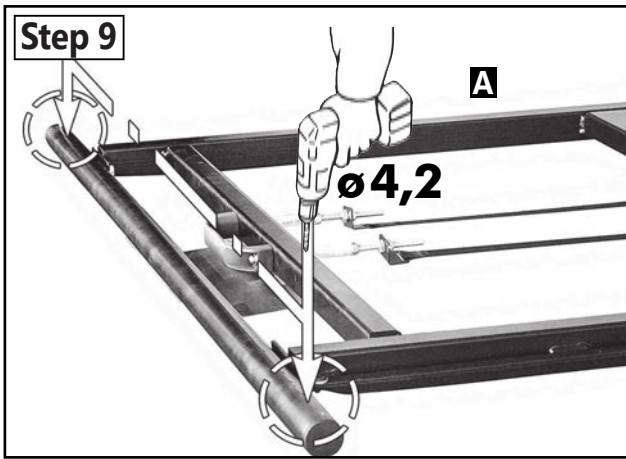

**article-no:**  
15U5690N black

**Revision 6:** 11.02.2019



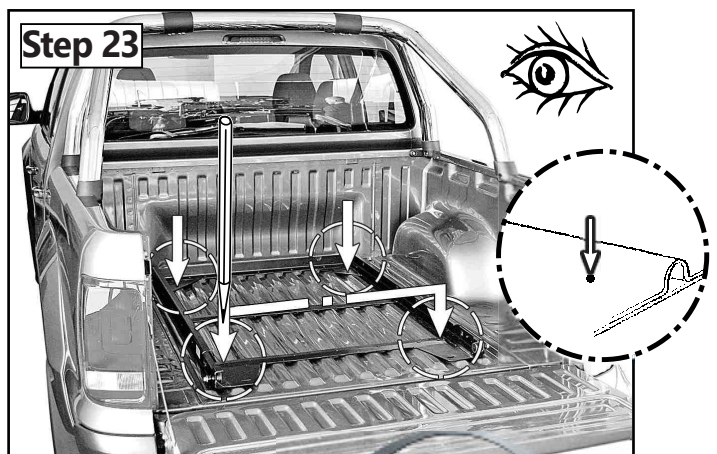
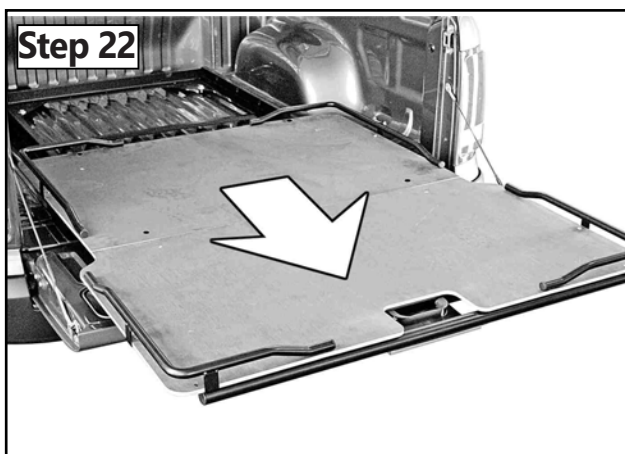
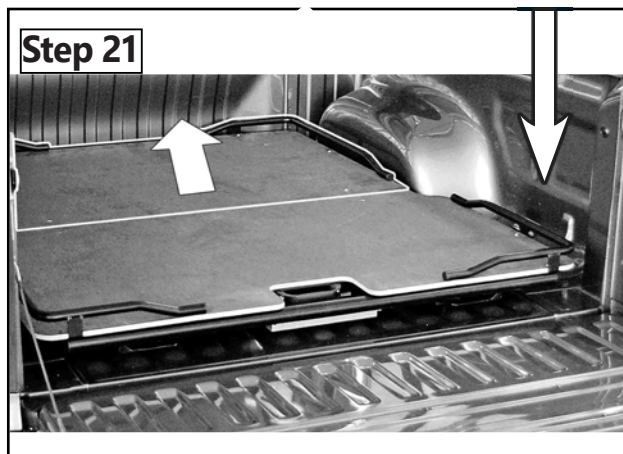
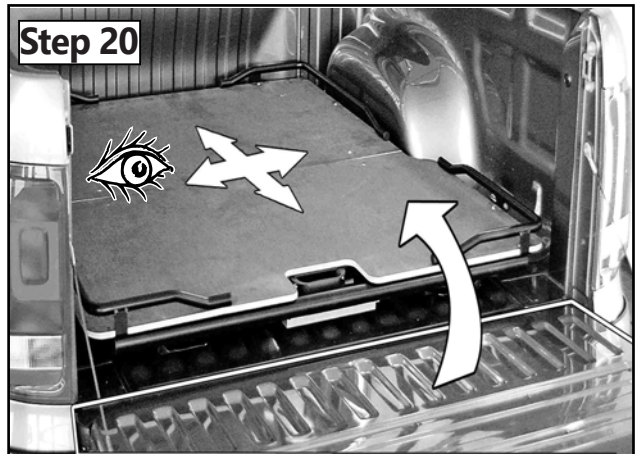
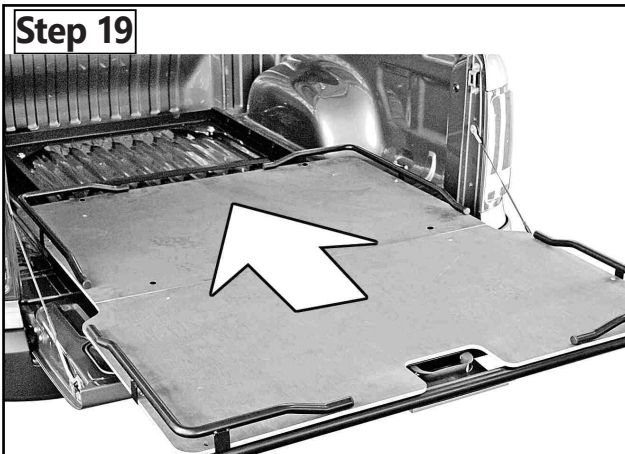
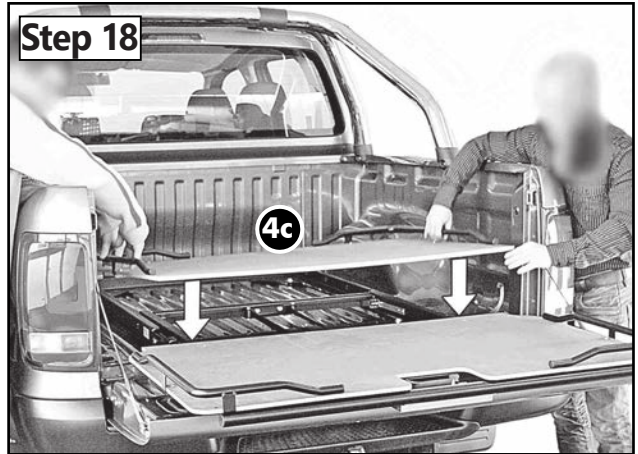
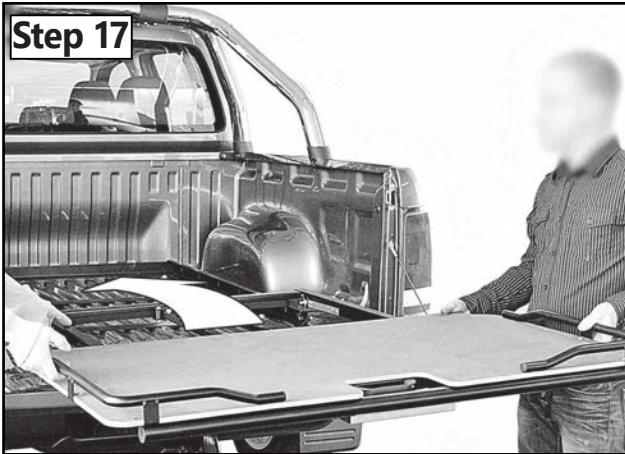

**article-no:**  
15U5690N black

**Revision 6:** 11.02.2019



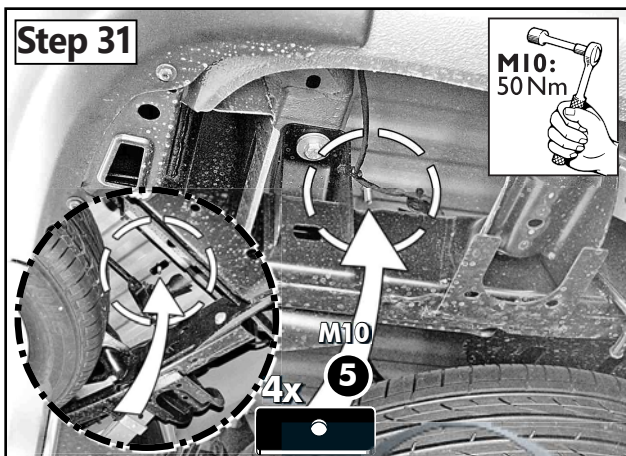
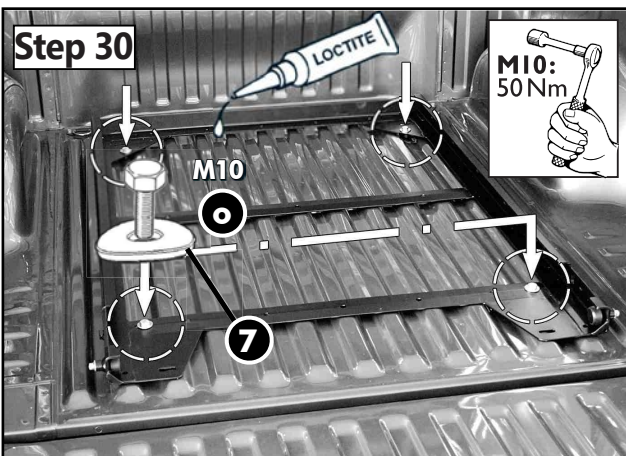
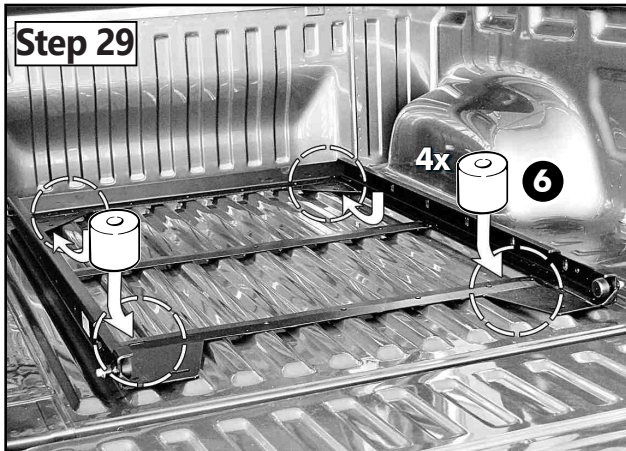
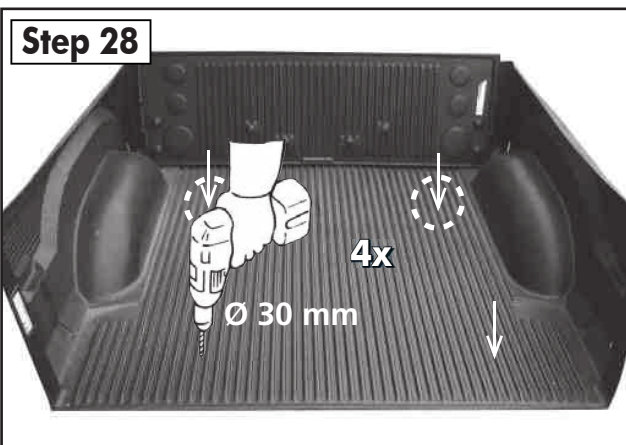
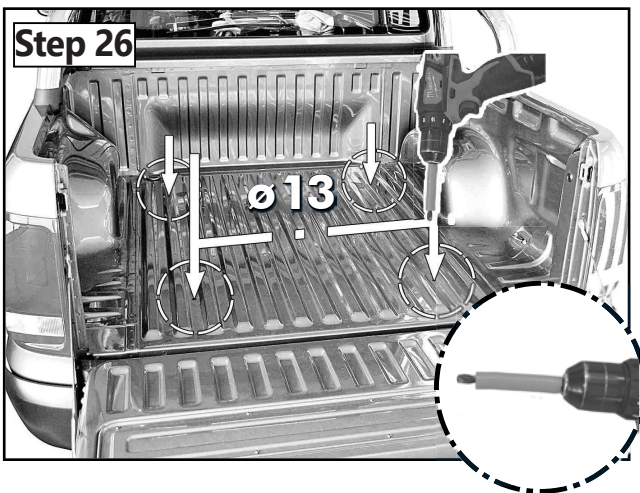

**article-no:**  
15U5690N black

**Revision 6:** 11.02.2019





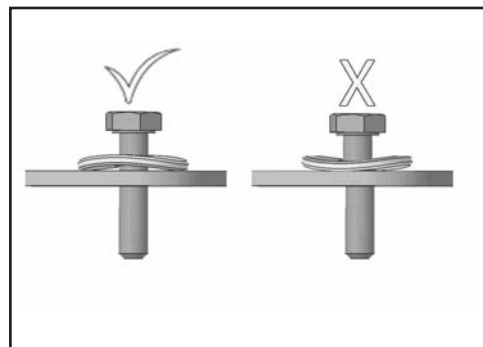
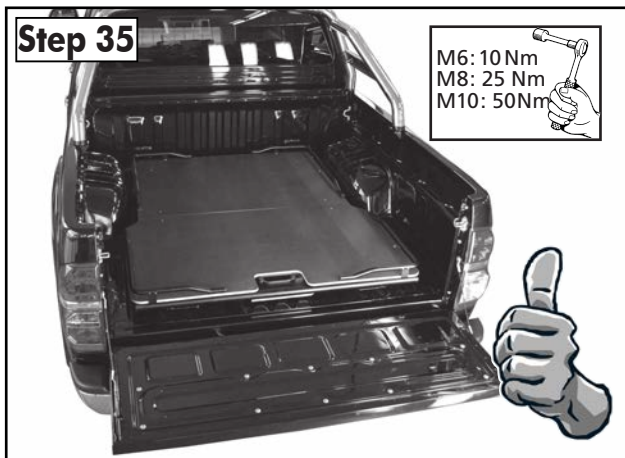
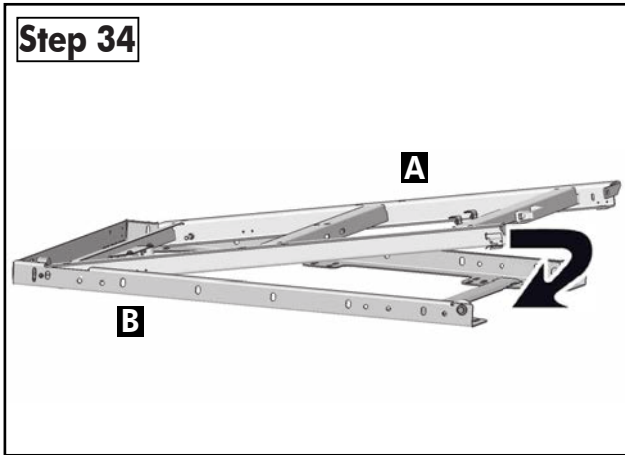
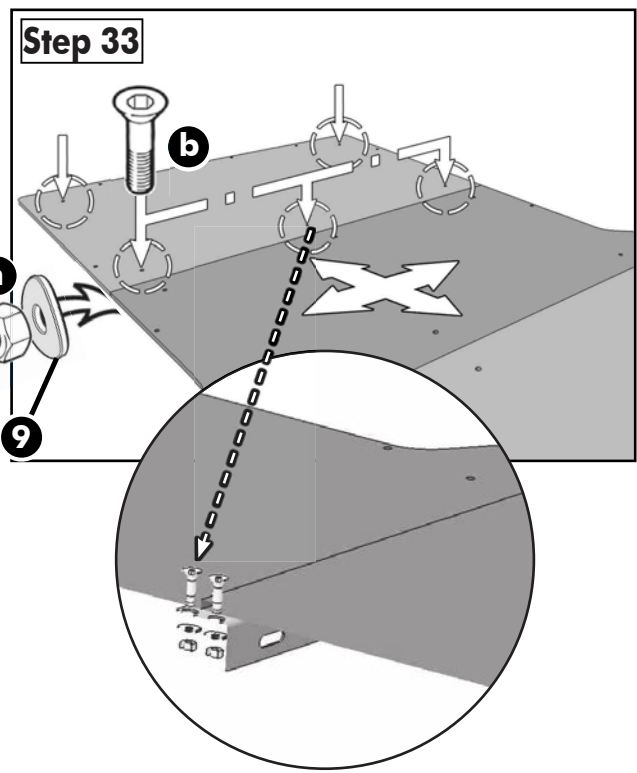
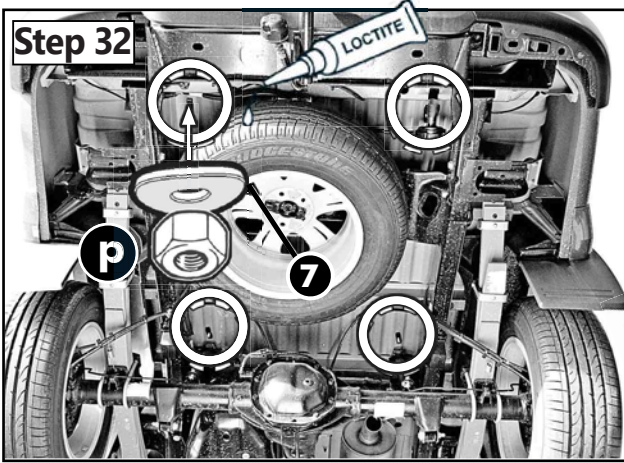

**350 kg  
max**



**article-no:**  
15U5690N black

**Revision 6:** 11.02.2019

