

**15V
4519**

Ford Ranger Md.2016

Styling bar 60
Stylingbügel 60
Arceau 60



for vehicles with leadframe please
order additionally 15V9520
für Fahrzeuge mit Leiterrahmen be
stellen sie bitte zusätzlich 15V9520
véhicule avec châssis en échelle ordre
en outre 15V9520



ASSEMBLY INSTRUCTION

Montageanleitung • Instructions de montage

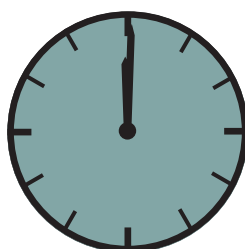

60 Minuten

article no.:

15V4519 (S) inox

15V5519 black steel

Revision 4: 08.07.2019



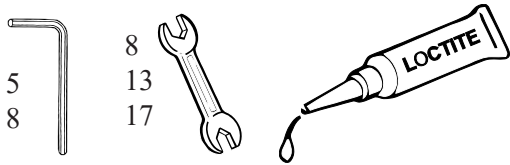

M5(A2): 5,1 Nm
 M8(A2): 21,4Nm
 M8: 25 Nm
 M10(A2): 44Nm
 M10: 50 Nm

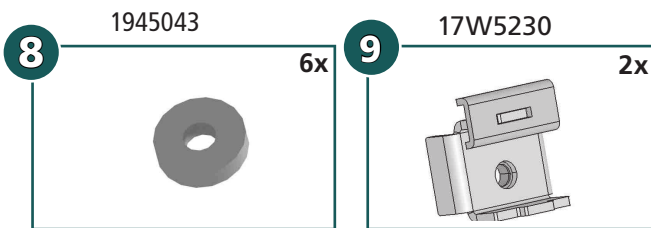
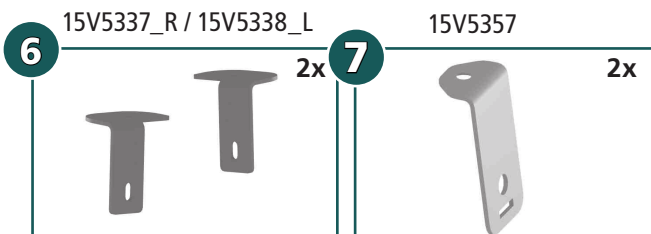
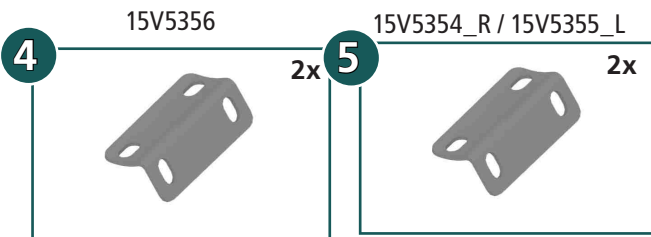
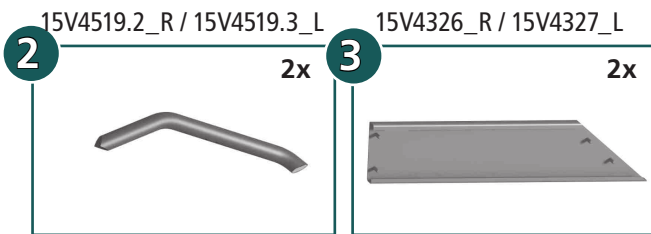
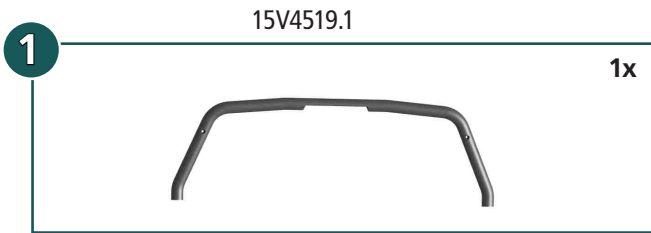

a		M10x30; DIN 912 A2	2x
b		M5x20; DIN 933 A2	8x
c		M8x30; DIN 933 Zn	2x
d		M10x40; DIN 933 Zn	2x
e		M8x25; DIN 7991 A2	4x
f		M5; DIN 985 A2	8x
g		Ø8; DIN 127 Zn	2x
h		ø5,3; DIN 125 A2	16x
i		ø8,4; DIN 9021 Zn	2x
j		ø10,5; DIN 125 Zn	2x
l		SW8	16x
m		SW17	2x
n		Gummi Stopfen Art.Nr. 0561 116	2x

Step 1

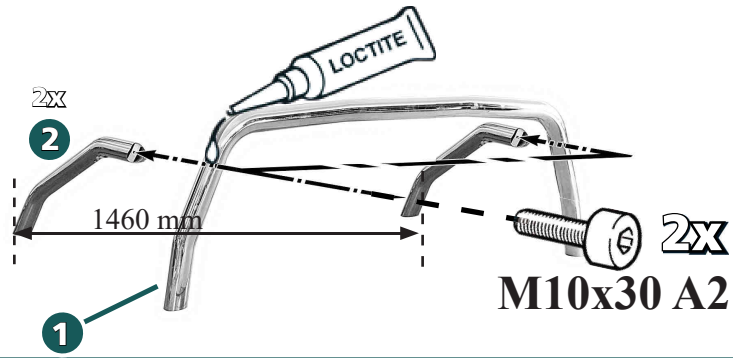

Step 2



Step 3

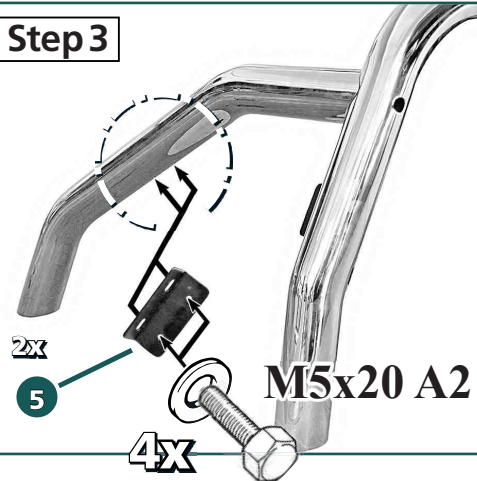

Step 4

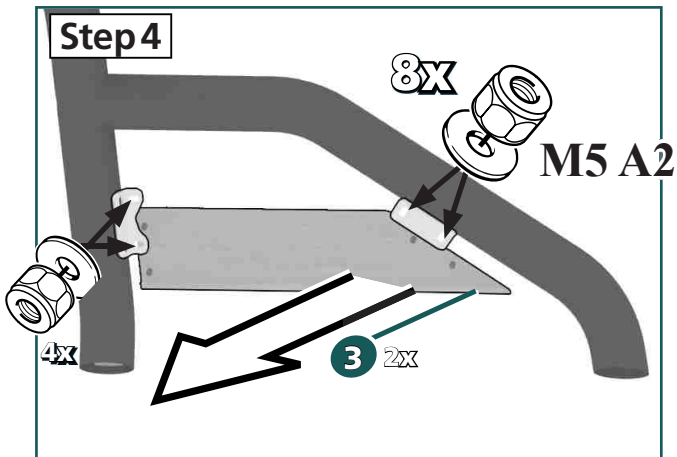

Step 5

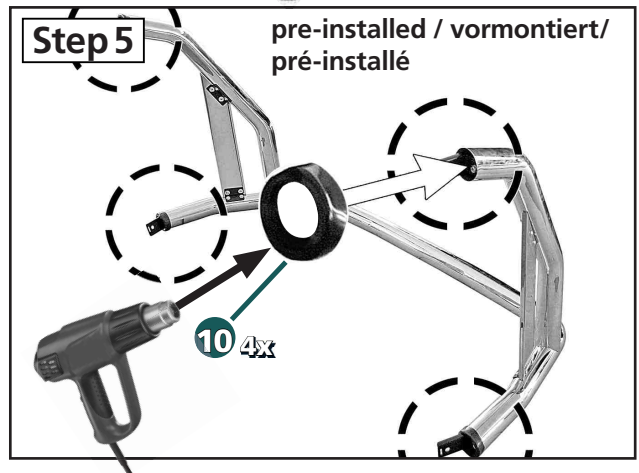

Step 6

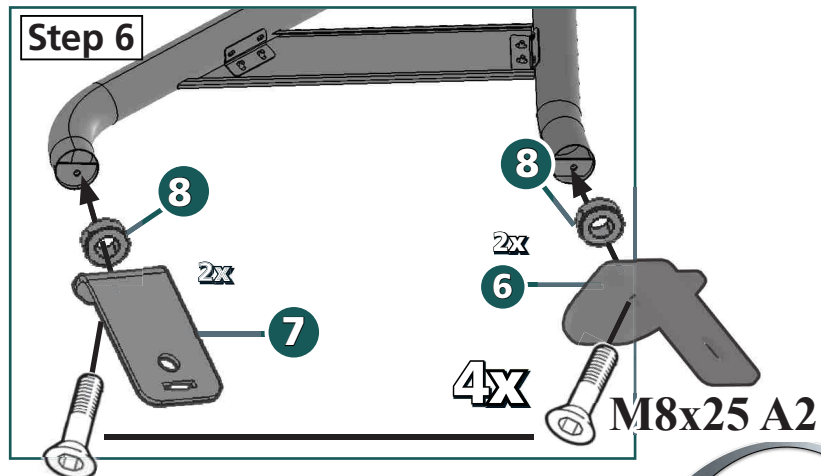

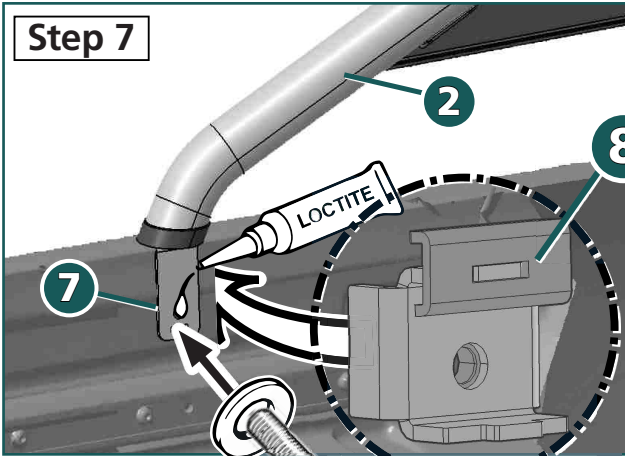

M10x40
2x
SW 17

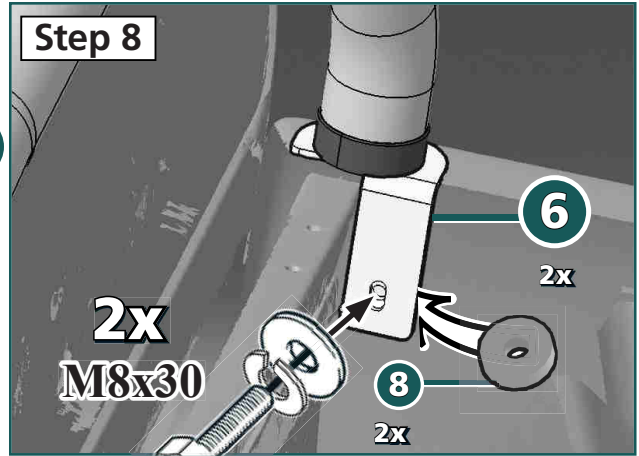

2x
M8x30

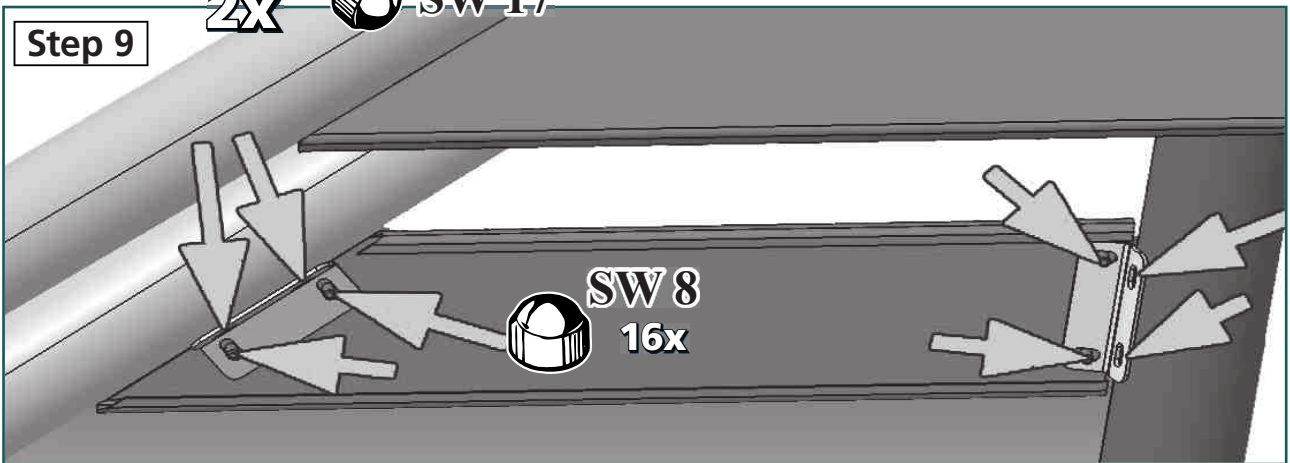

SW 8
16x

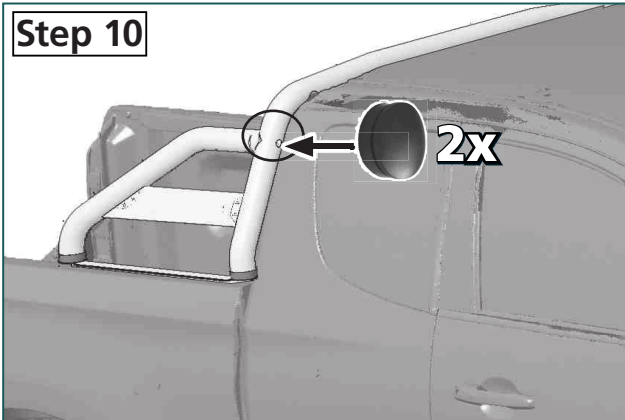

2x



M5(A2): 5,1 Nm
M8(A2): 21,4Nm
M8: 25 Nm
M10(A2): 44Nm
M10: 50 Nm