

**16H  
4413**

## Mitsubishi Outlander 2012 / 2014

EU-Pedestrian Protection Bar 60 mm with cross pipe 42 mm

EU-Personenschutzbügel 60 mm mit Querrohr 42 mm

Protection avant, homologuée CEE, 60 mm, traverse 42 mm



\*Compatible with Automatic Cruise Control /Forward Collision Mitigation  
Kompatibel mit Abstandsregeltempomat /Auffahrvermeidungs-oder warnsystem  
compatible avec radar de régulation de distance/ freinage autonome d'urgence

# ASSEMBLY INSTRUCTION

Montageanleitung • Instructions de montage

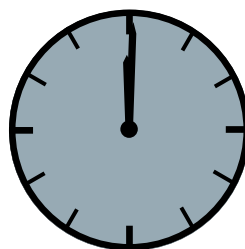

**60 Minuten**

### Artikel-Nr:

16H4413 stainless steel

16H5413 black steel

16H9413 Assembly-kit

Revision 2: 14.03.2016

M6:  
10 Nm  
M8(A2):  
21,4 Nm



10  
13

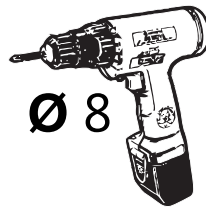
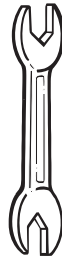

Ø 8



5

TX 10

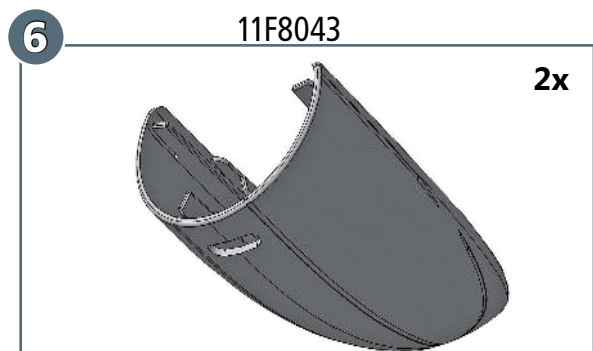
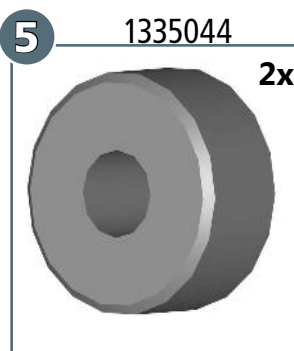
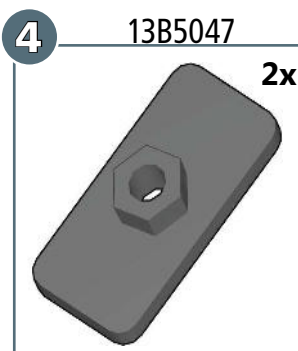
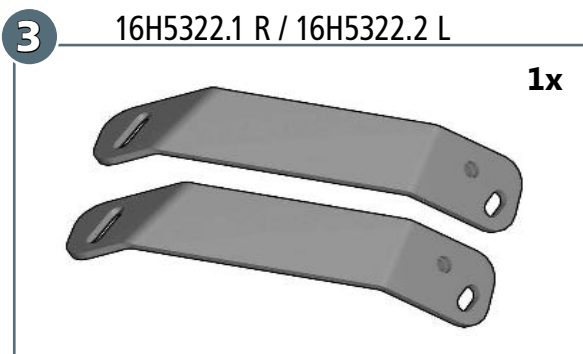
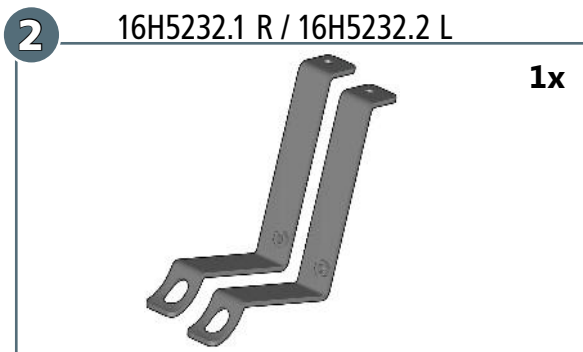
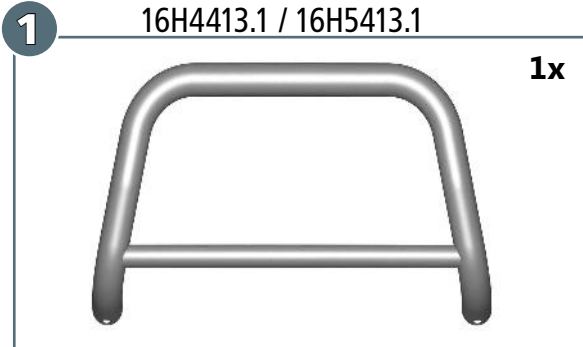

<b>a</b>		M6 x 20; DIN 933 Zn	<b>6x</b>
<b>b</b>		M8 x 20; DIN 933 A2	<b>2x</b>
<b>c</b>		M6 x 30; DIN 912 Zn	<b>2x</b>
<b>d</b>		Ø 3,5 x 13, ähnl. 7981B A2	<b>2x</b>
<b>e</b>		Ø 4,2; DIN 9021 A2	<b>2x</b>
<b>f</b>		Ø 6,4; DIN 9021 Zn	<b>6x</b>
<b>g</b>		Ø 6,4; DIN 125 Zn	<b>2x</b>
<b>h</b>		Ø 8,4; DIN 9021 A2	<b>2x</b>
<b>i</b>		Ø 6; DIN 127 Zn	<b>8x</b>
<b>j</b>		Ø 8; DIN 127 A2	<b>2x</b>
<b>k</b>		SW 13 mm	<b>2x</b>

