

START HERE!

READ ME FIRST

Don't be a hero and muscle through this installation without reading these fitting instructions first! Improper installation of this gear may void certain aspects of your warranty.

Before you begin, take a moment and open all your Front Runner rack kit boxes and gather the assembly instructions for the various components.

A complete kit will contain:

1. A Front Runner Mounting System specific to your vehicle
2. A Front Runner Rack Tray or Load Bar Slats

This document will guide you through the assembly of the mounting system and assist you in fitting the roof rack tray or load bars to your specific vehicle.

Please refer to the next page for a list of all the components, quantities and tools required.

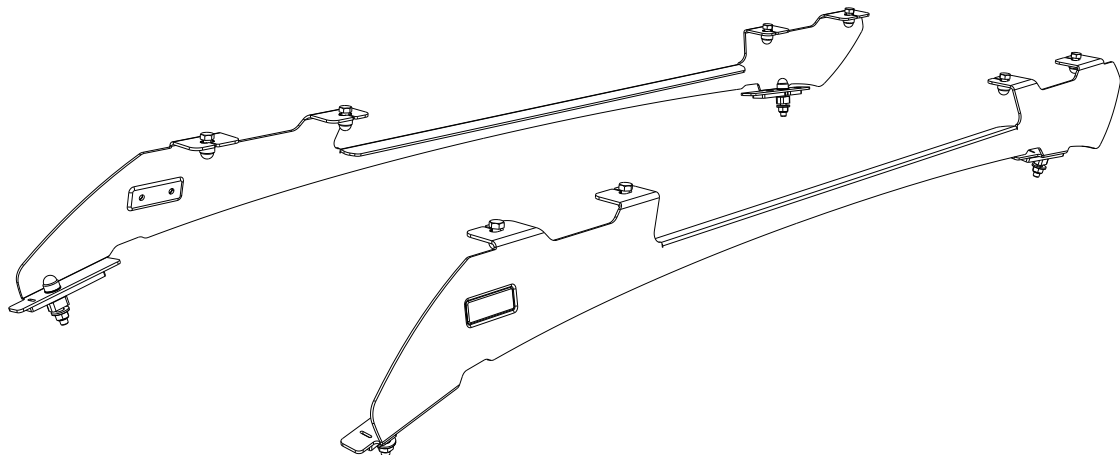

IMPORTANT WARNING! ⚠

IT IS CRITICAL THAT ALL FRONT RUNNER PRODUCTS BE PROPERLY AND SECURELY ASSEMBLED AND ATTACHED TO YOUR VEHICLE. IMPROPER ATTACHMENT COULD RESULT IN AN AUTOMOBILE ACCIDENT, AND COULD CAUSE SERIOUS BODILY INJURY OR DEATH. YOU ARE RESPONSIBLE FOR ASSEMBLING AND SECURING ALL FRONT RUNNER PRODUCTS TO YOUR VEHICLE, CHECKING THE ATTACHMENTS PRIOR TO USE, AND PERIODICALLY INSPECTING THE PRODUCTS FOR ADJUSTMENT, WEAR AND DAMAGE. THEREFORE, YOU MUST READ AND UNDERSTAND ALL OF THE INSTRUCTIONS AND PRECAUTIONS SUPPLIED WITH YOUR FRONT RUNNER PRODUCT PRIOR TO INSTALLATION OR USE. IF YOU DO NOT UNDERSTAND ALL OF THE INSTRUCTIONS AND CAUTIONS, OR IF YOU HAVE NO MECHANICAL EXPERIENCE AND ARE NOT THOROUGHLY FAMILIAR WITH THE INSTALLATION PROCEDURES, YOU SHOULD HAVE THE PRODUCT INSTALLED BY A PROFESSIONAL INSTALLER OR OTHER QUALIFIED PERSONNEL.

NOTE: Front Runner will not be responsible for any damage caused by the failure to install the product according to these instructions.

Please call us if you have any questions about the installation of this product.



1 GET ORGANIZED

IN THE BOX

1	2 X	Foot Rail 1LH + 1RH
2	8 X	M8 x 20 Hex Head Bolt
3	8 X	M8 x 16 x 1.6 Flat Washer
4	12 X	M8 Nyloc Nut
5	12 X	M8 Nut Cap
6	4 X	M8 x 19 x 2 Flat Washer
7	4 X	M8 x 40 Hex Head Bolt
8	2 X	Front Spacer Top
9	2 X	Rear Spacer Top
10	4 X	Bottom Spacer

TOOLS NEEDED

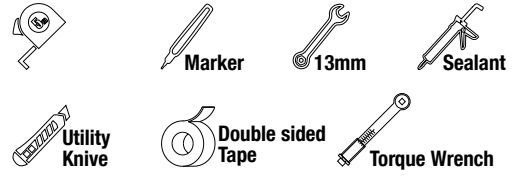
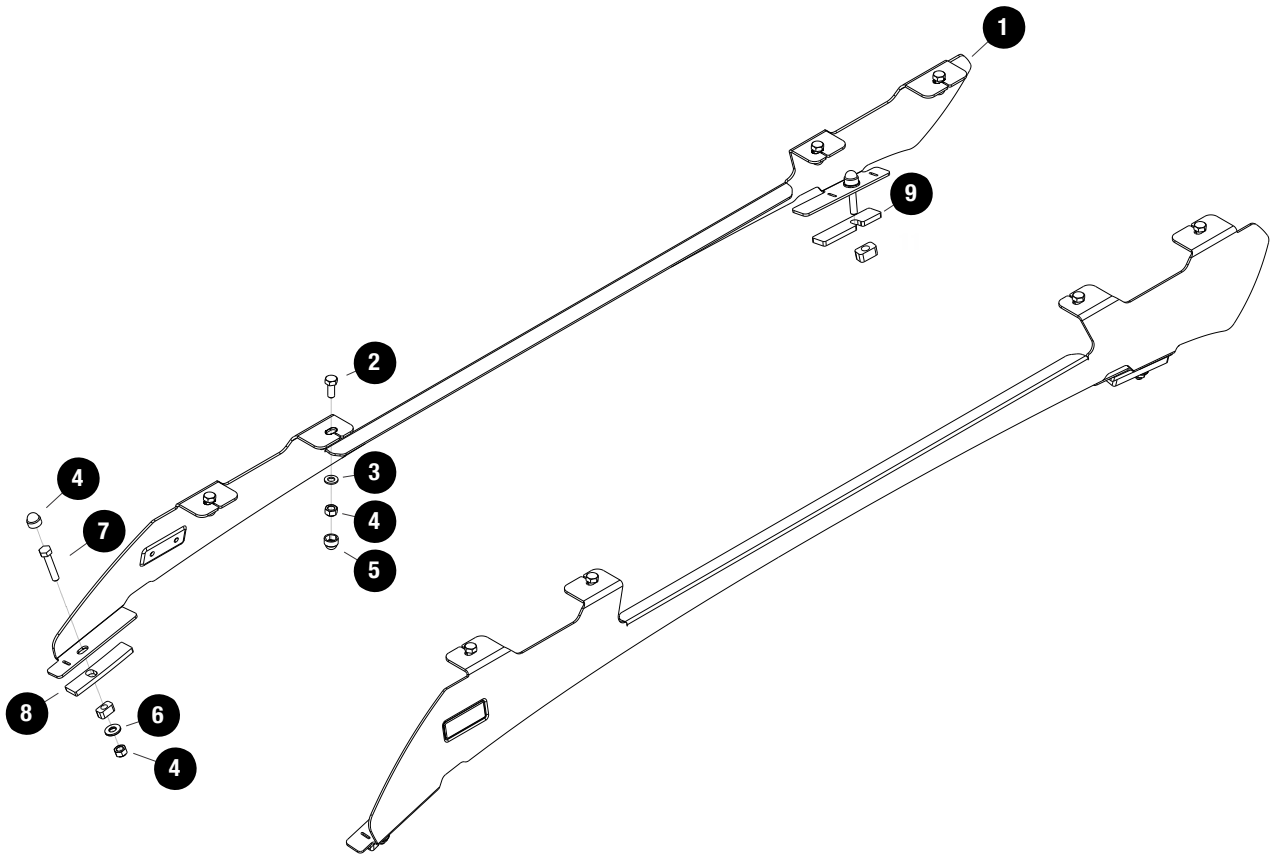

FIGURE 1.1

Tightening Torque:

M8 : 15-20Nm / 11.06 ft lb - 14.75 ft lb



2.1



Drop the vehicle's roof lining.



Look online for videos to assist.

2.2

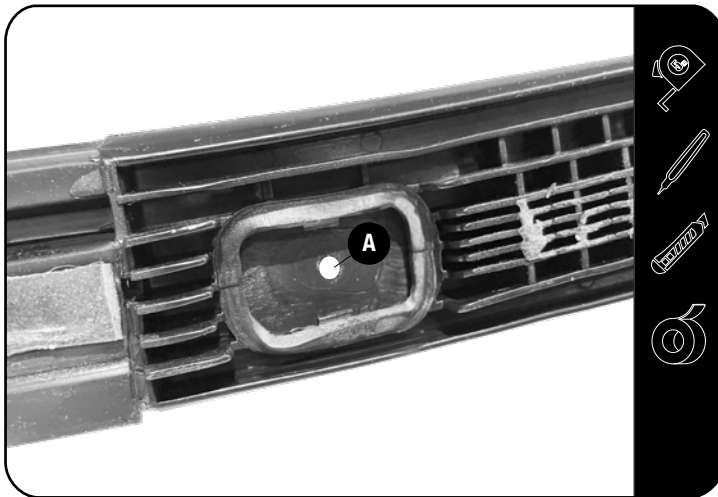

Remove the Ditch Mold from the vehicles roof. Remove the Nut insert from the plastic trim and place the Bottom Spacer (Item 10) into the opening and mark the center of the hole (A). Drill a 6mm Pilot hole and open it to a 8.5mm Hole. Refit the Ditch Trim with the Bottom Spacer in place

Models without factory Roof Rails.

Models with factory Roof Rails.

Remove the top factory fitted roof rails.

2.3

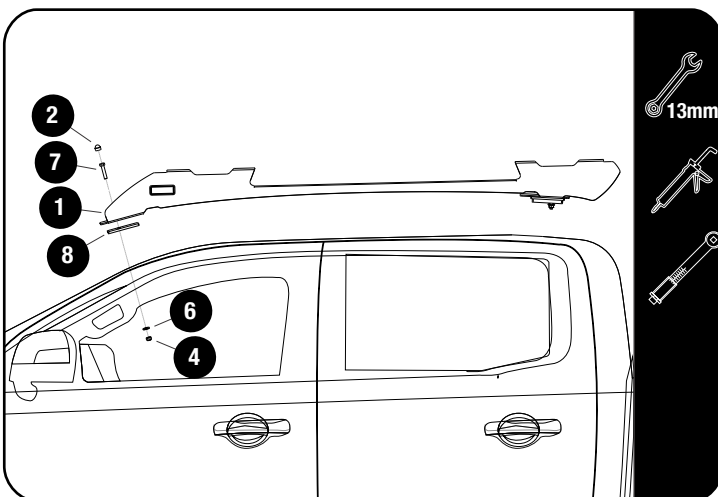

Apply Sealant over the 4 holes on the outside of the roof.



Models with factory Roof Rails will only use 6mm Spacers Item 8 & 9.

Models without factory fitted Roof Rails will use all the spacers supplied.



Place the Spacers that suit your model (Items 8, 9 & 10) over the holes. Refer to Fig 1.1 for Spacers positioning.

Apply a bead of sealant on the threads of the M8 x 40 Hex Bolts and secure the Foot Rail (Item 1) to the Roof using M8 x 40 Hex Head Bolts, M8 x 19 x 2 Flat Washers and M8 Nyloc Nuts (Items 4, 6 & 7).

Place M8 Nut Caps (Item 5) over all M8 Nyloc Nuts (Item 4).

3

FIT AND SECURE

3.1

Refer to RRSUNI when assembling your Slimline II Tray.



3.2

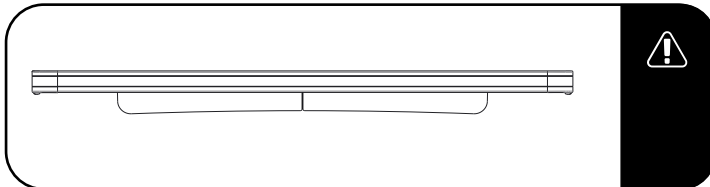

Make sure that the wind deflector is installed before you proceed to the next step.

3.3

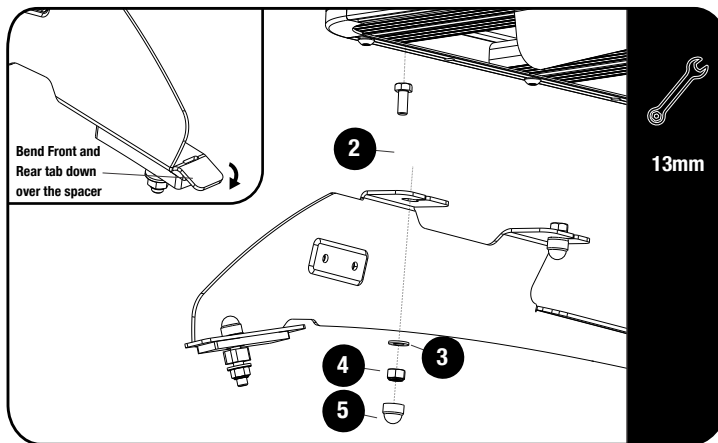

Fit your roof rack to the Foot Rails using M8 x 20 Hex Bolts, M8 x 16 x 1.6 Flat Washers and M8 Nyloc Nuts (Items 2, 3 & 4) as shown.



Tightening Torque:

M8 : 15-20Nm / 11.06 ft lb - 14.75 ft lb

Bend the finishing tab down as shown in Fig3.3

3.4

Center the rack and tighten fully. Use M8 Nut Caps (Items 10) to finish off the nuts.



5

INSTALL OTHER VEHICLE AND RACK ACCESSORIES

Now's the time to visit your favorite Front Runner dealer in person or online.

IMPORTANT!

FRONT RUNNER RACK KITS OFTEN HAVE A HIGHER LOAD RATING THAN THE VEHICLES THEY ARE MOUNTED TO. PLEASE REFER TO YOUR SPECIFIC VEHICLE MANUFACTURER FOR A RECOMMENDED ROOF RATING. FRONT RUNNER CANNOT BE RESPONSIBLE FOR IMPROPER LOADING BEYOND THE VEHICLE MANUFACTURER'S STATED LOAD CAPACITY.

Be sure to tag us. We love to see our gear in action! #FrontRunnerOutfitters #BornToRoam

Share your adventures on: