

# 6 Way Master Switch MINI Controller

## 1. Wiring Instructions

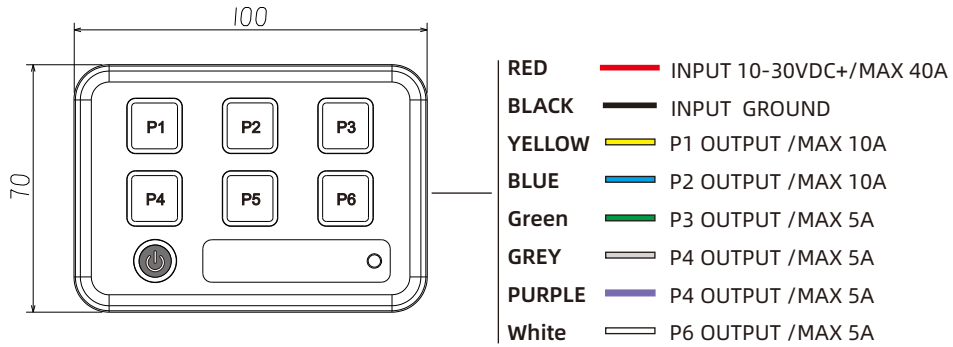

## 2. ENTER Programming Mode

### 2.1: Latching/Momentary Setting

- To enter programming mode ensure that the controller is switched OFF.
- PRESS and HOLD the centre ON/OFF master switch button, whilst depressed, push the corresponding Switch that you would like to program from ON/OFF latching to Momentary activation which will be confirmed by an audible tone.
- Repeat this procedure to program each of the 4 available switches.

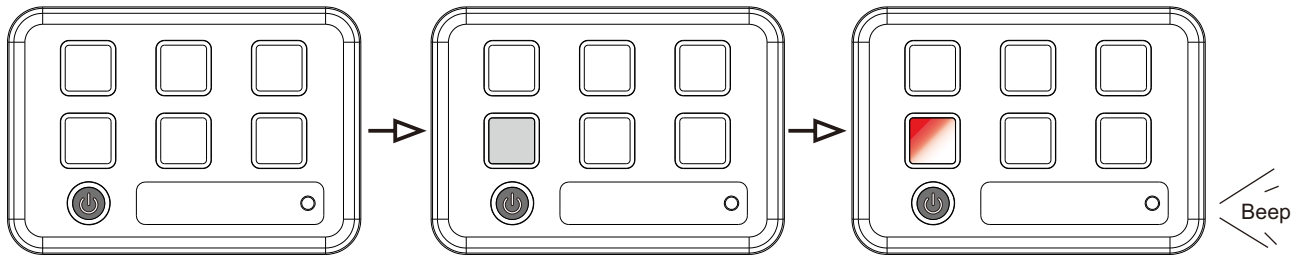

### 2.2: Master/Slave Setting (Group mode)

- Power on the controller, press and hold the button to be set as the master, keep it until a BEEP sound. Then press the button to be set as the slave.
- Cancellation: Power on, press and hold the master button, keep it until a BEEP sound, then press the slave button to cancel
- Remarks: After set successfully of Master/Slave button, the slave button can still be controlled independently.

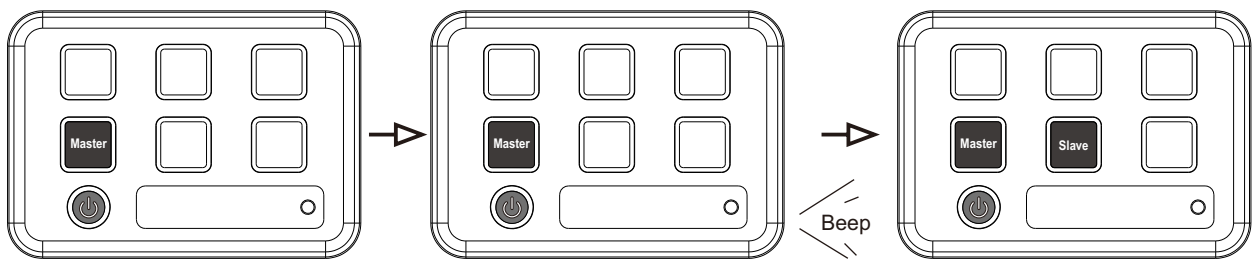

## 3. Mounting

### 3.1: 3M Sticker mount

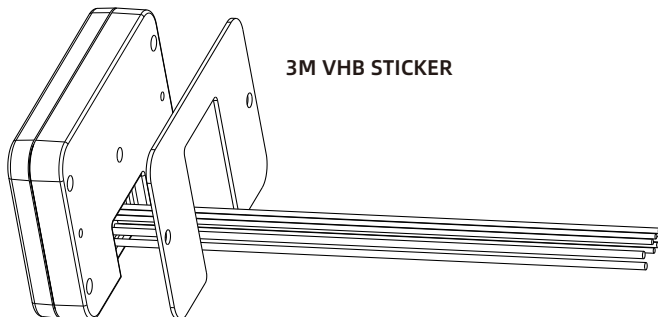

### 3.2: Bracket mount

